

BSA Norton

TRIUMPH

NORTON Fork Crown & Column Lock Nut B2/205 (No.43) new replica £12. Good used £6-00

NORTON Steering Damper Adjusting Spring B2/202 (No.45) £2-50

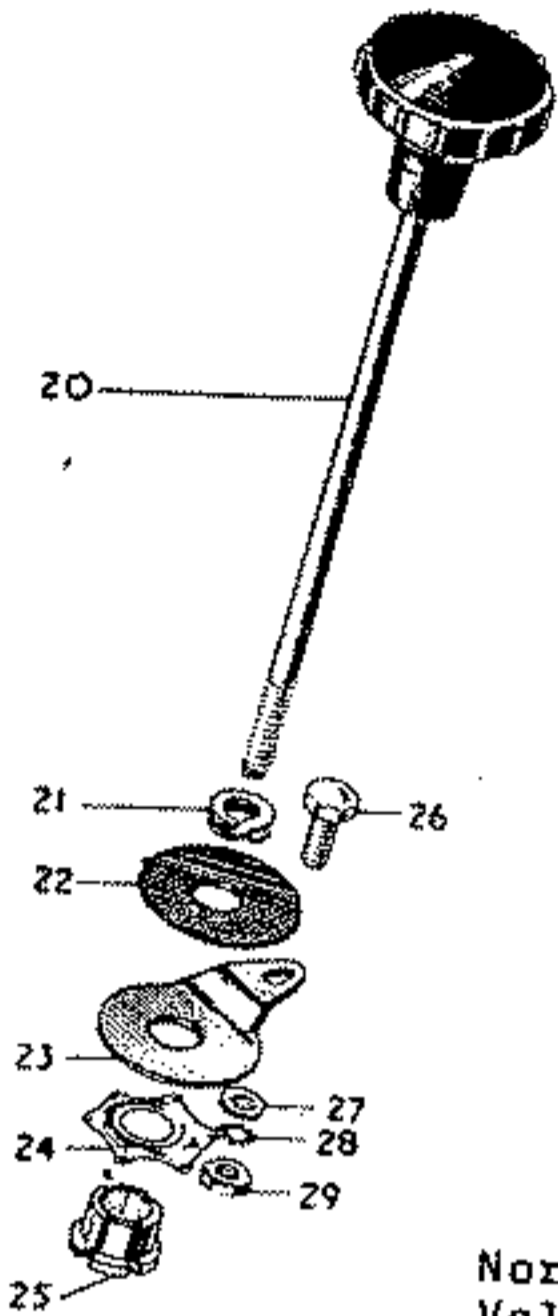

Norton International Manx 30-40 Velo, André Steering Damper Two Discs £8-00

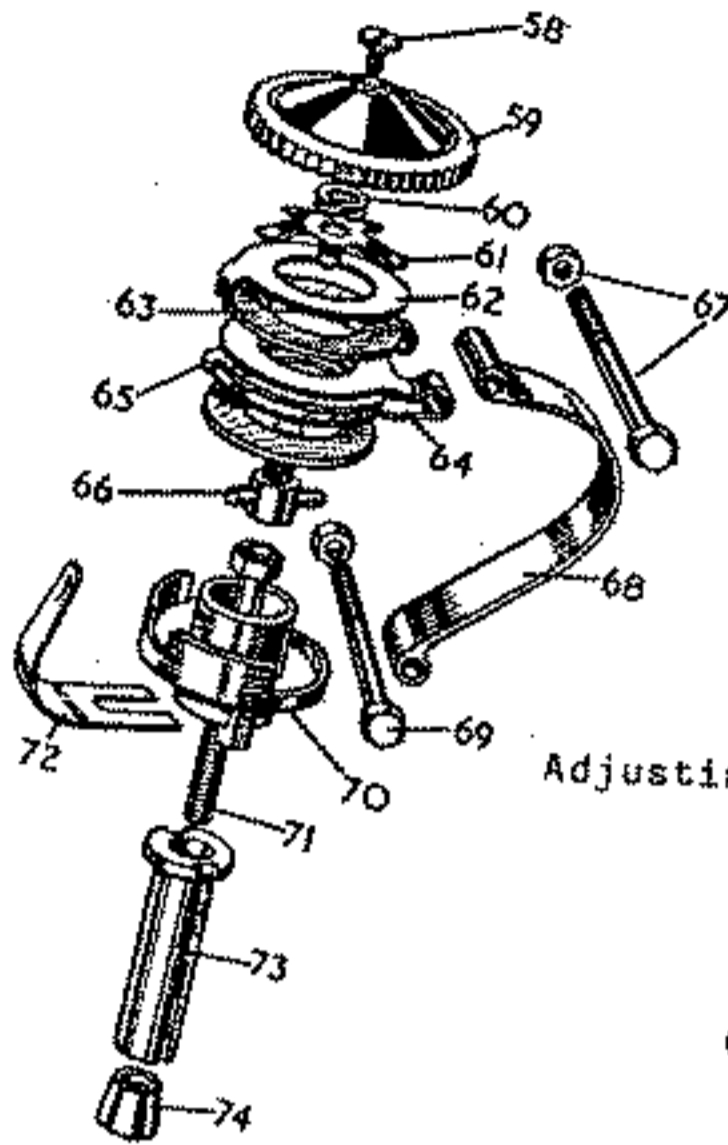

Steering Damper Adjusting Rod B2/203 £6-00

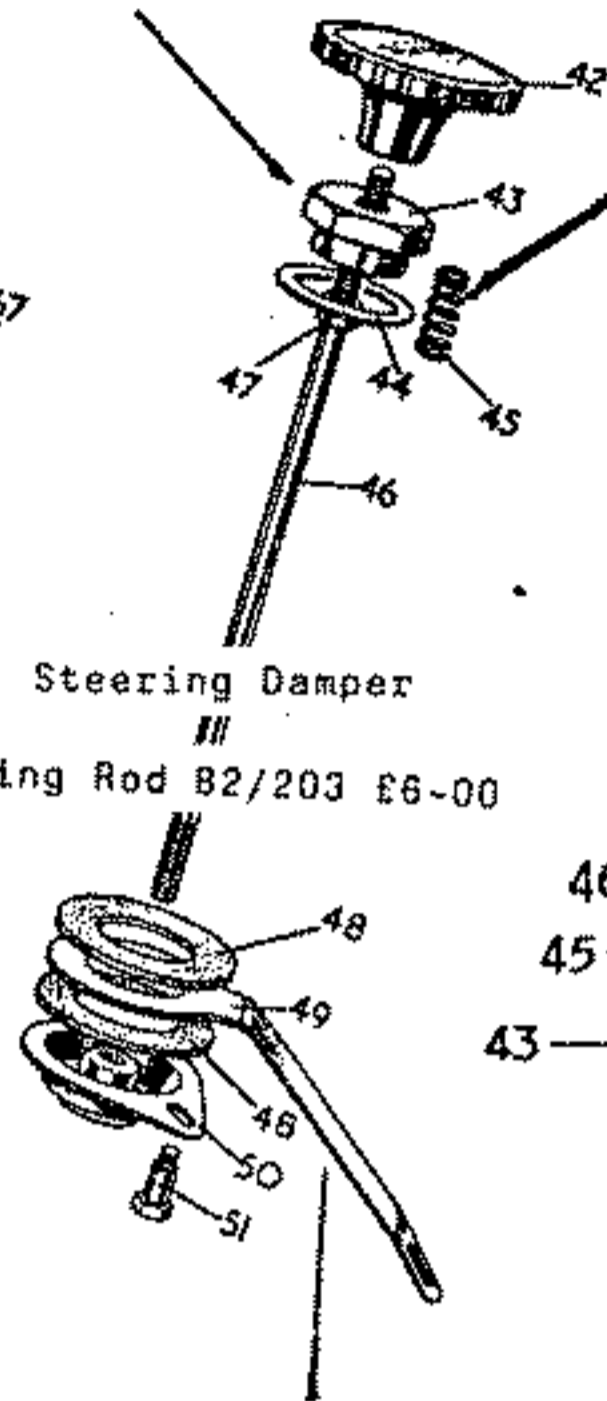

Steering Damper Friction & Anchor Plate B2/206 - 8 1/4 long unpainted £12-00

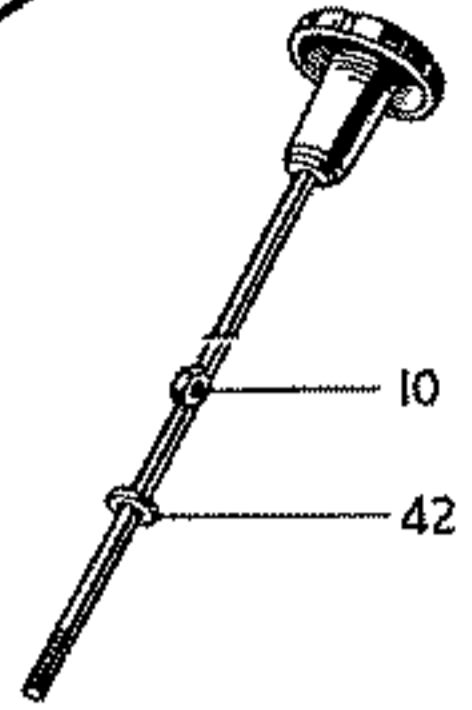

Friction washer, steering damper

GIRDER FORK FRICTION DISCS

PANTHER

MODELS 100 & 120

AJS PRE WAR GIRDER FORK	£8-00	pair	2 needed	FR14
MATCHLESS/AJS AMC DAMPER	£5-00	pair	2 needed	FR6
NORTON FEATHERBED DAMPER	£3-00	1	needed	FR3
BSA B/M/A SERIES DAMPER & Y13/G14/J12	£5-00	pair	2 needed	FR4
ROYAL ENFIELD DAMPER	£8-00	pair	2 needed	FR13
NORTON LONG ROADHOLDER DAMPER	£2-80	1	needed	FR2
RUDGE ULSTER/SPECIAL DAMPER	£8-00	pair	2 needed	FR7
RUDGE ULSTER/SPECIAL GIRDER FORK	£8-00	pair	2 needed	FR8
VELOCETTE MOV/MAC/GTP/MSS DAMPER	£8-00	pair	2 needed	FR9
RED PANTHER WEBB FORK	£8-00	pair	2 needed	FR12
TRIUMPH DAMPER	£3-00	1	needed	FR5
PANTHER HEAVYWEIGHT DAMPER	£8-00	pair	2 needed	FR1
BROUGH DRUID FORK	£8-00	pair	2 needed	FR10
BSA GIRDER FORK Y13 & G14 V TWINS/M20WD	£8-00	pair	2 needed	FR11
VELOCETTE WEBB GIRDER FORK (SIDE) from 1925 also fits EXCELSIOR MANXMAN	£3-50	each	No	33F
VELOCETTE STEERING DAMPER (WEBB GIRDER) also fits EXCELSIOR MANXMAN 1930 onwards				
WEBB FORKS	£2-25	each	No	20M

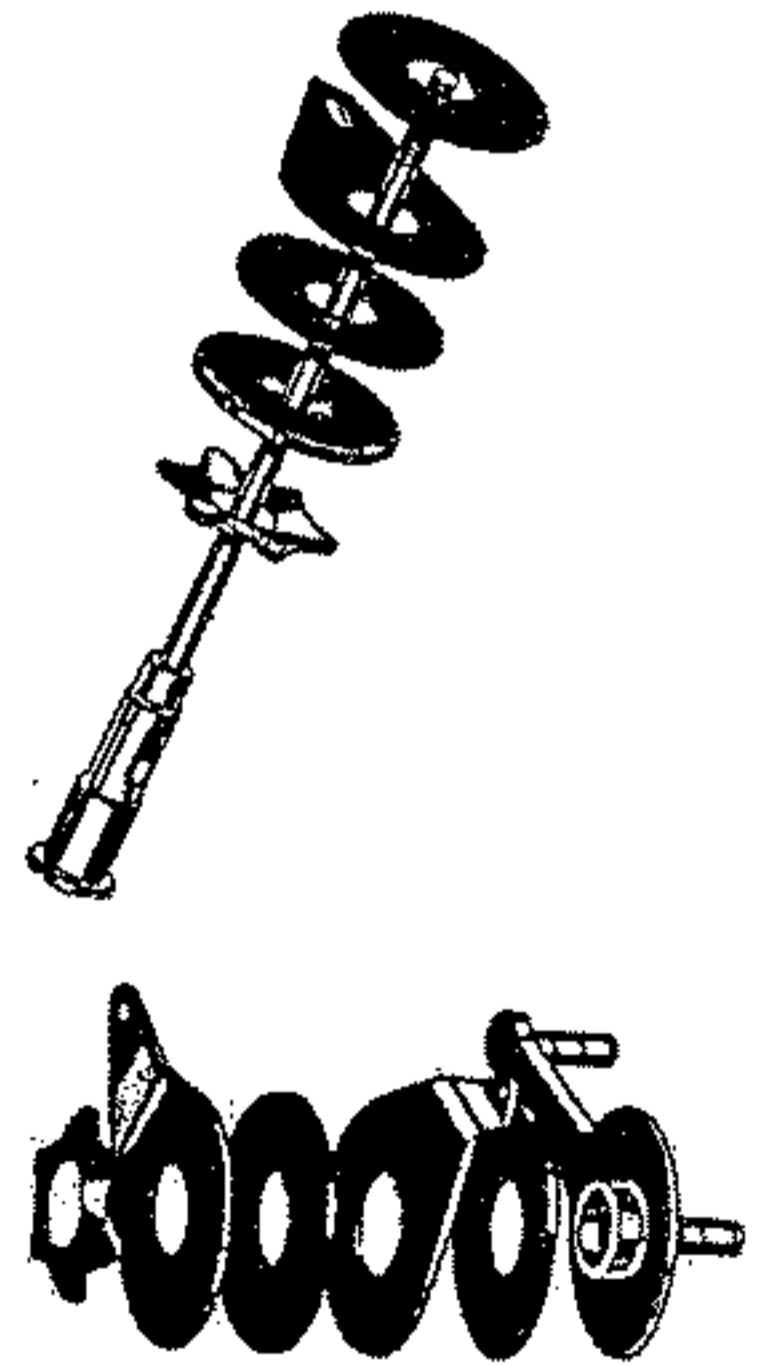

BSA M20 Girder Fork x 2

Norton Webb Girder Fork 2 needed Genuine Norton £12-00 pair FR15

NORTON GIRDER FORK STEERING DAMPER (BOTTOM) EURO 8 EACH (TWO NEEDED)
 TRIUMPH H.WEIGHT GIRDER (SIDE DAMPER) EURO 7.75 EACH (TWO NEEDED)
 ARIEL GIRDER H.WEIGHT (SIDE DAMPER) P.T NO.4665-34 EURO 7.75 (ONE NEEDED)

ARIEL STEERING DAMPER GIRDER+TELES 1926-58 P.T. NO 4665-26 EURO 6 EACH (1. OR 2. NEEDED)

CORNUCOPIA ENTERPRISES
 IN DER GRUND 2
 0-37647 VAHLBRUCH

**LEVERS TO FIT ARIEL
TRIUMPH 1938 - 1950
AMAL TYPE
ALSO BOWDEN
IN STOCK**

AJS

MATCHLESS

TRIUMPH

Norton

all Parts Replica

Bowden civil & W.D. Levers

all Parts Replica and unpainted
alle Teile sind Nachbau und unlackiert
Castings cast in Brass and unpainted.
Will also need some minor fine work
to remove excess brass before fitting.

Our unchromed Bowden replica Bracket
(6416 A.39 Front Brake) or (6415 A.39
Clutch) fitted with 1950s Doherty Air
or Mag Lever (chrome) as shown on Page
8 No.326 drilled & tapped to fit 6415
F.34 & 6415 G.34 Screws. Chrome Doherty
Lever 7/8 or 1" £16-50 ea. not incl.
Bracket.

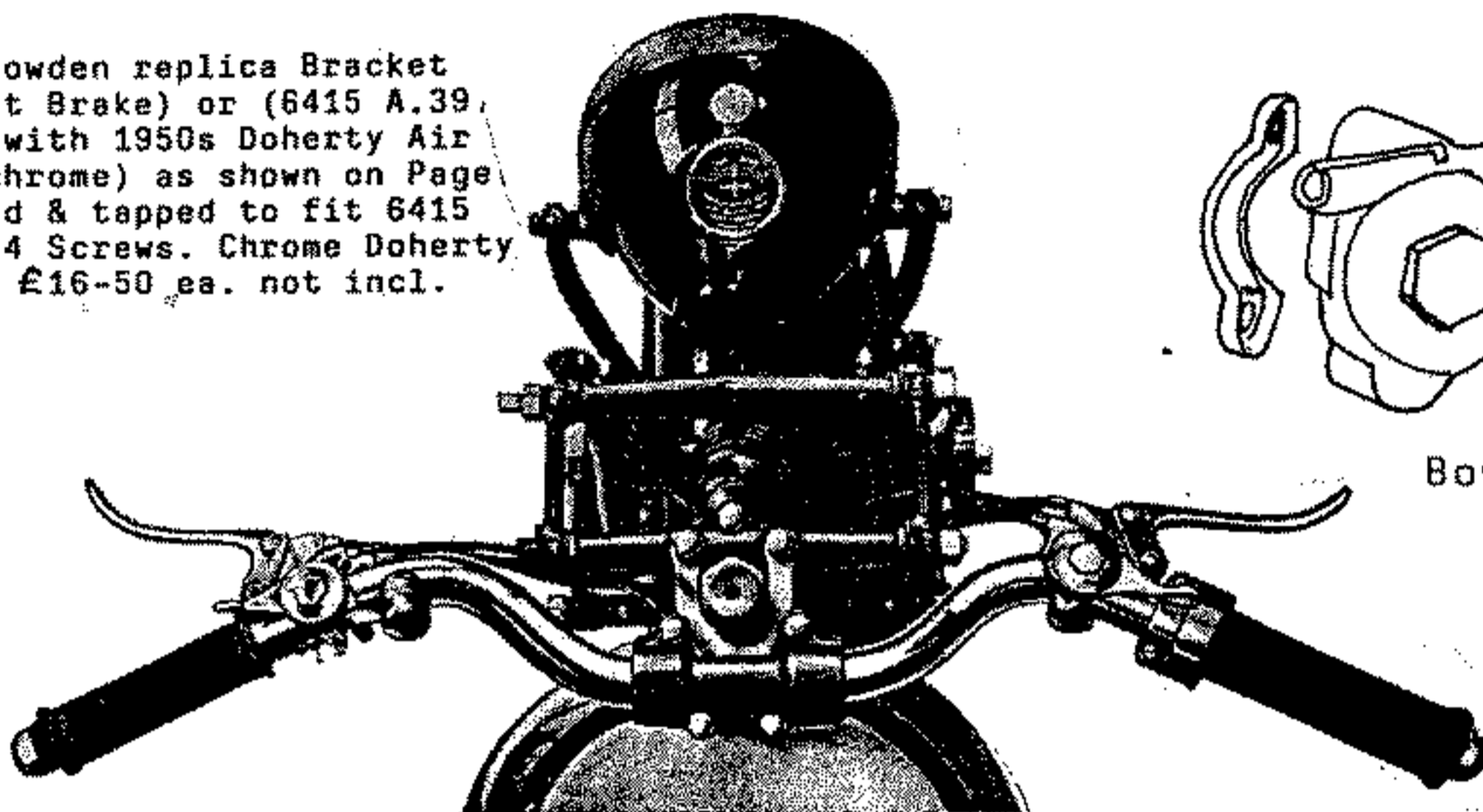

Norton Handlebar Layout 1935

Showing Combined Air/Mag Levers

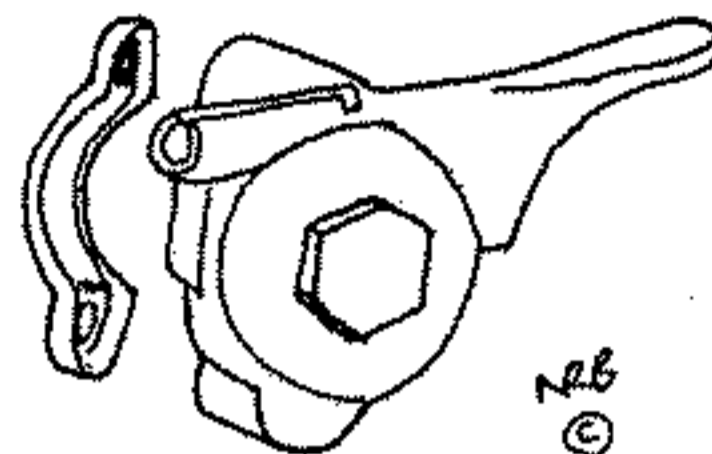

Bowden Type

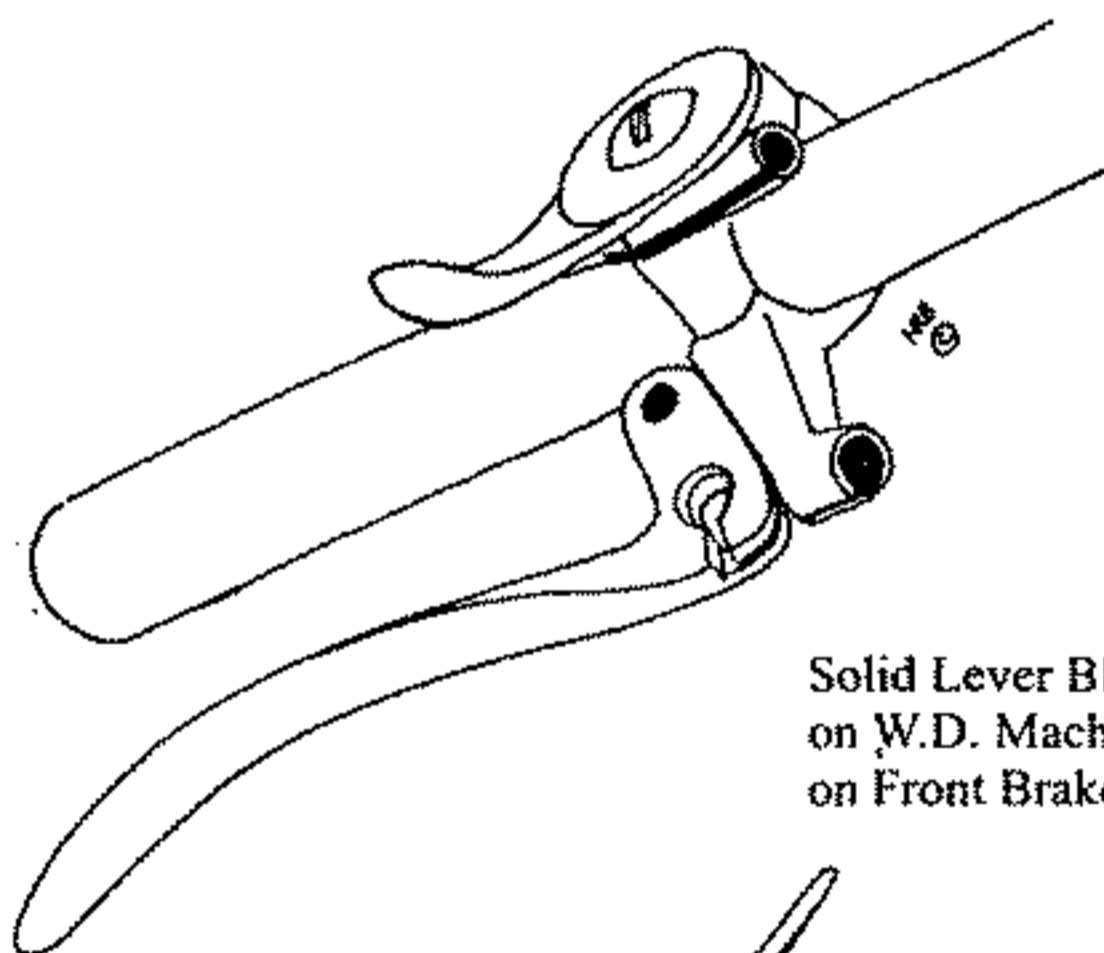

Solid Lever Blade Brass
on W.D. Machines - left Hand Clutch Lever is used
on Front Brake Side (upside down)

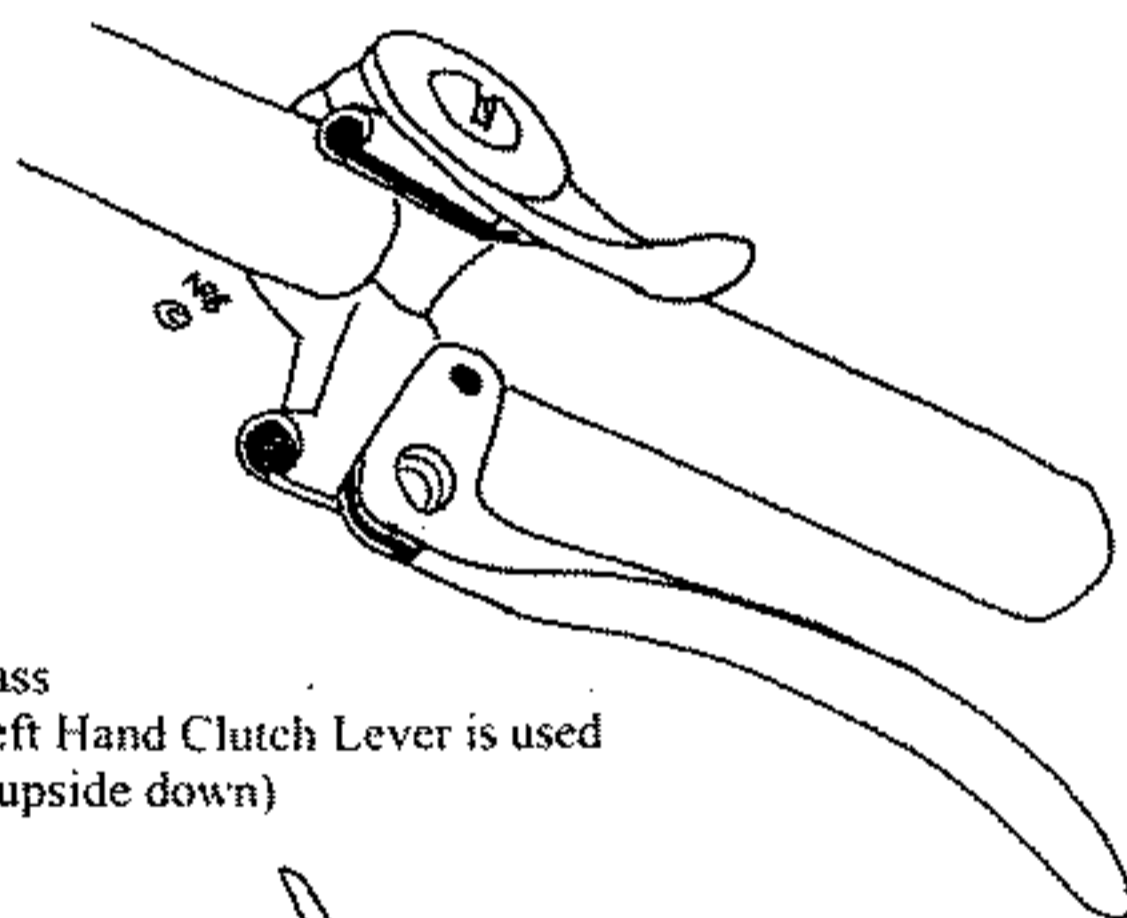

6415b-34

6415b-34

6415 A-39

Clutch Bracket

State if 7/8 or 1" Dia left or right Hand

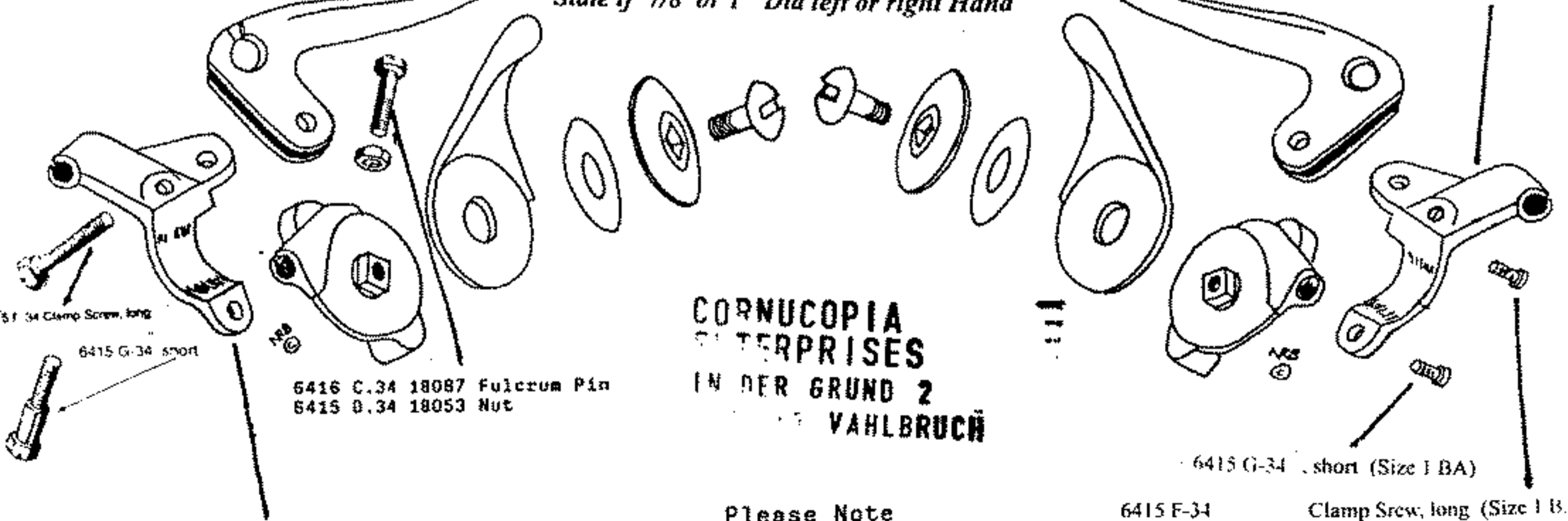

**CORNUCOPIA
ENTERPRISES
IN DER GRUND 2
VAHLBRUCH**

Please Note

Air & Mag Levers shown on this page
are Doherty chrome, a cheaper alternative to Bowden Lever.

Sold only complete 16-50 each

6416 A-39 Front Brake Bracket
DRAWINGS BY
N.R. BRIDWELL
GERMANY

6415 F-34

Clamp Screw, long (Size 1 B)

6415 G-34 short (Size 1 BA)

6416 C.34 18087 Fulcrum Pin
6415 B.34 18053 Nut

6415 G-34 Clamp Screw, long

6415 G-34 short

**LEVERS TO FIT ARIEL
TRIUMPH 1938 - 1950
AMAL TYPE
ALSO BOWDEN
IN STOCK**

Unapproachable
Norton
(REGD TRADE MARK)
Motor Cycle

MATCHLESS

AJS

MUCOPIA
CORNUCOPIA
ENTERPRISES
IN DER GRUNDVAHLBRUCH
D-37547 VAHLBRUCH

ALL PARTS REPLICAS

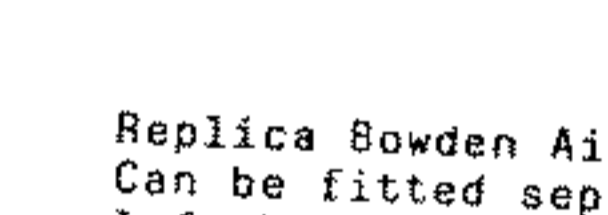
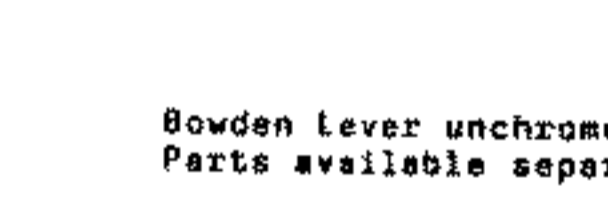
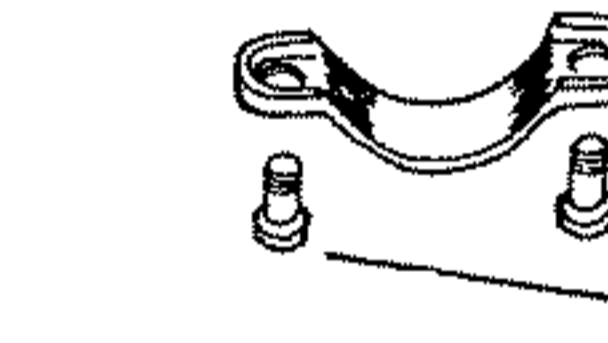
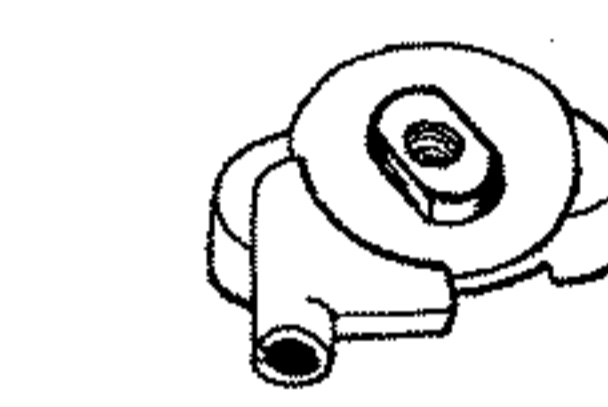
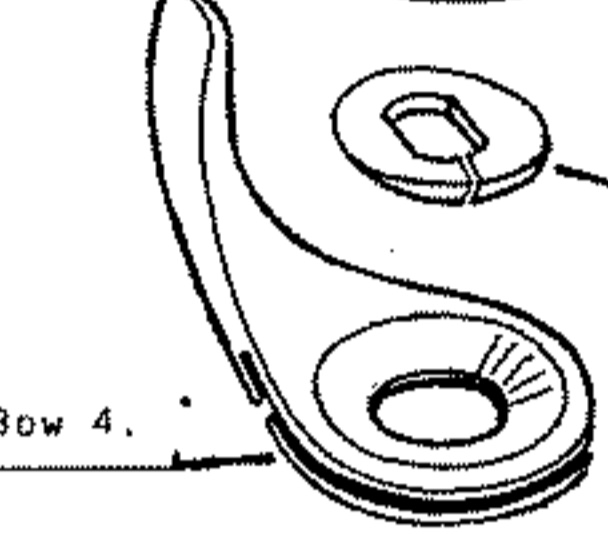
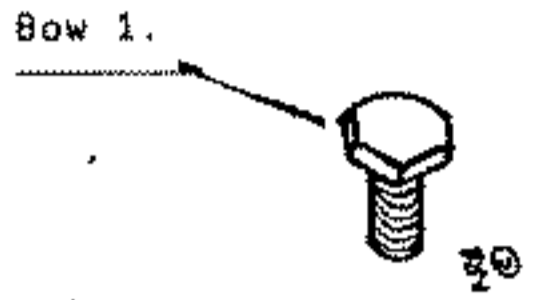

Bowden	Single Lever
Bow 1.	£1-50
Bow 2.	£4-00
Bow 3.	£3-00
Bow 4.	£14-00
Bow 5.	£14-00
Bow 6.	£4-50
Bow 7.	£1-25 ea.

£43-50

Bowden	Double Air Mag Lever
Bow D1.	£1-50
Bow D2.	£4-00
Bow D3.	£0.30
Bow D4.	£3-00
Bow D5.	£16-00
Bow D6.	£1-50
Bow D7.	£3-00
Bow D8.	£16-00
Bow D9.	£16-00
Bow D10.	£4-50
Bow D11.	£1-25 ea.

£68-30

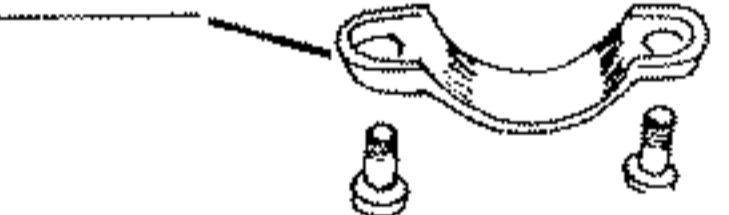
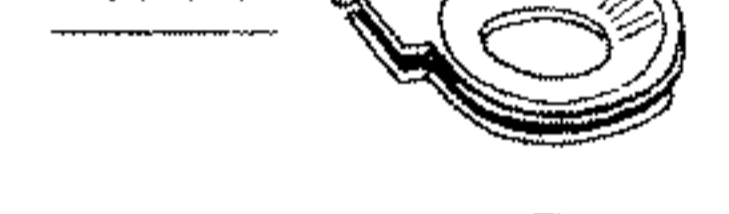
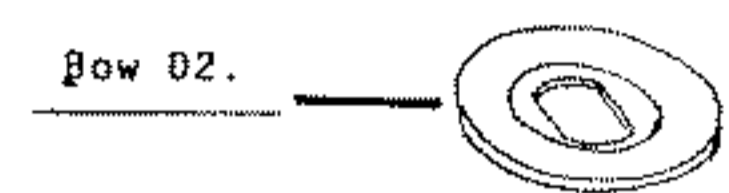
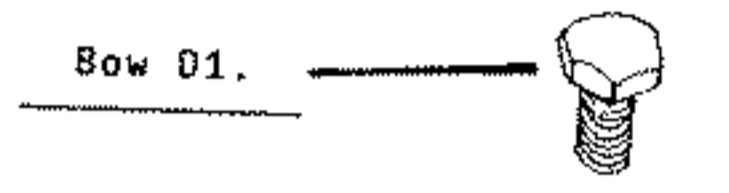

Bowden Lever unchromed
Parts available separately

Replica Bowden Air or Mag Lever
Can be fitted separately with clamp 7/8 or 1" dia. right or left hand or fitted to Combination Levers, see Page 116.

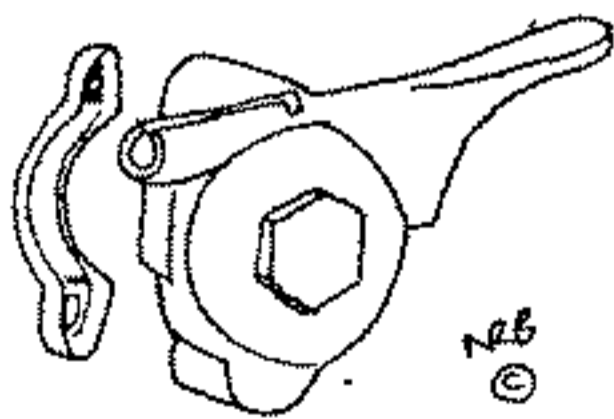

Bowden Lever unchromed
Parts available separately

Replica Bowden Double Air Mag Lever (right hand side)
only available in 1" (25.4mm) dia.

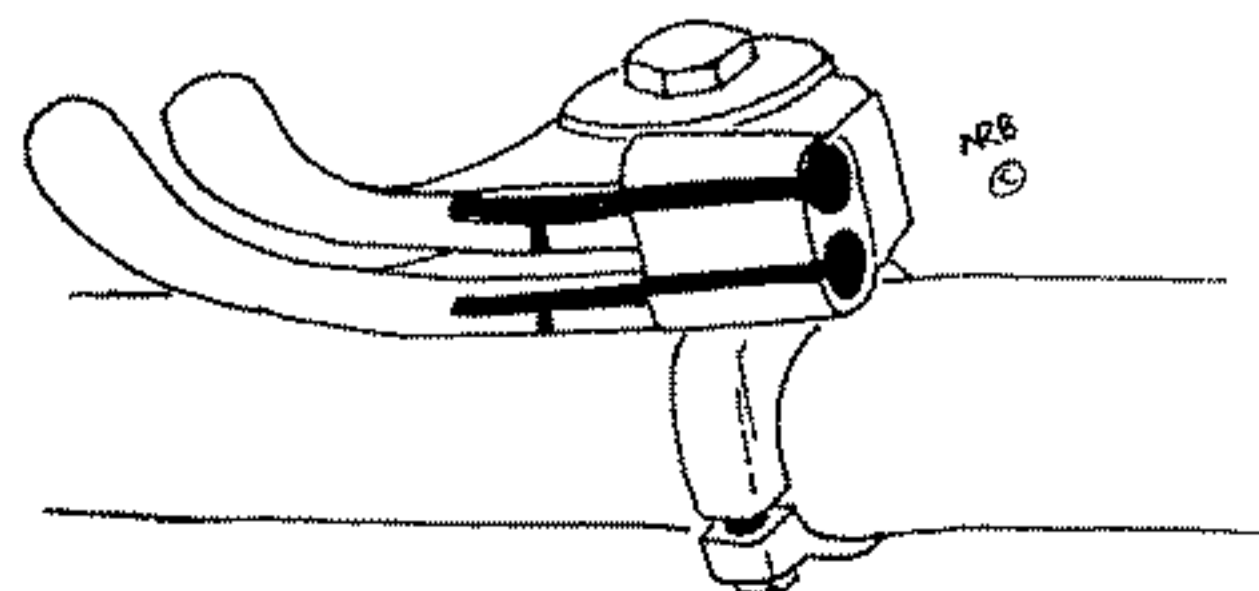

DRAWINGS BY
N.R. BRIDEWELL
GERMANY

State if 7/8 or 1" Dia left or right Hand