

SÜDAFRIKANISCHE
TOURIST TROPHY 1928

B. S. A.
Sieger
der Senior 600 ccm Klasse

B.S.A.

Steirische
Winterwertungsfahrt 1928
3 B.S.A. am Start
3 B.S.A.
STRAFPUNKTELOS
AM ZIEL!

MOTORRÄDER

sind wegen ihrer absoluten Verlässlichkeit
bei schonungslosester Beanspruchung

**DIE VERBREITETSTEN
IN DER WELT!**

CORNUCOPIA
ENTERPRISES
IN DER GRUND 2
D-37647 VAHLBRUCH

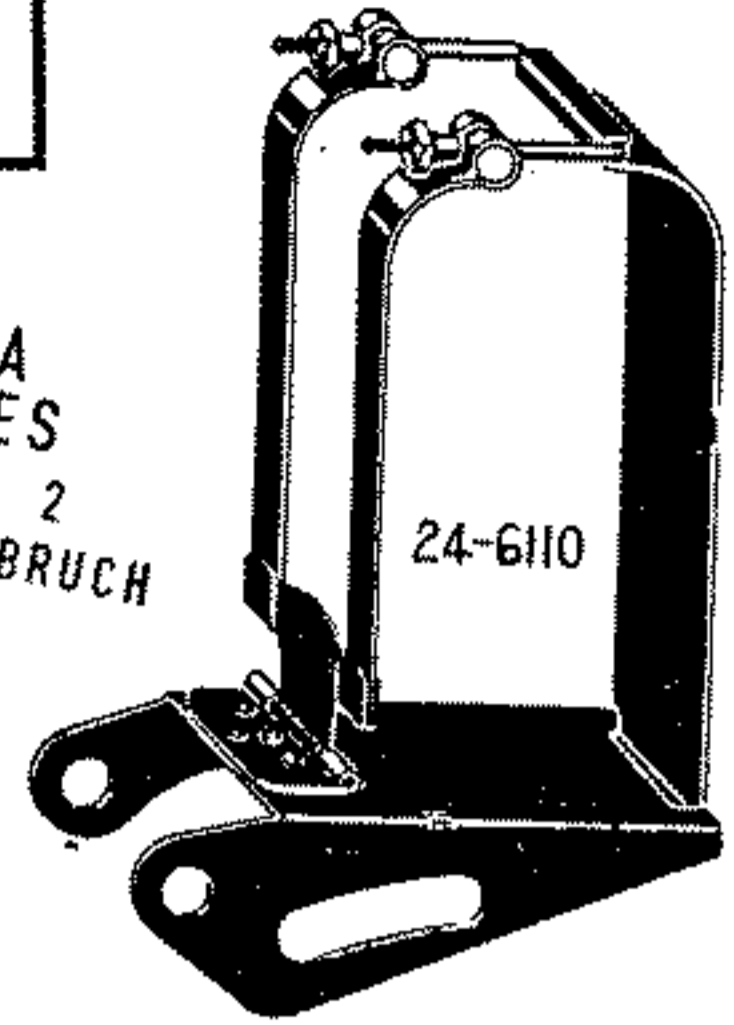

To fit BSA models 1930/31/32/33

Battery Carrier 24.6110 (Base not supplied)
Only front & rear straps & fittings.

Above Battery Straps fit the following models, (less base plate)

- 1930-3.49 O.H.V. L30-11
4.93 SV S30-7 S.V. De Lux S30-9
5.57 SV H30-8 S.V. De Lux H30-10
4.93 O.H.V. S30-12
4.93 OHV De Lux S30-13
- 1931- 4.93 S.V. & De Lux S31-7 H31-6
4.93 O.H.V. & De Lux S31-9 S31-10
- 1932- 4.93 O.H.V. De Lux S32-8
5.57 S.V. De Lux H32-9
- 1933- 5.95 S.V. De Lux M33-10
5.95 O.H.V. De Lux M33-11

- F.Strap 24/1, C/W Trunnions 16.50
R/Strap 24/2 10.00
Top Wire Clip 24/4 5.00
Nuts for above wire clip 24/5
1.25 each/pro stuck
Fixing Clip & Nuts 24/3 7.00

CHAINGUARD & FITTINGS.



27-8760 15-8696 24-8707 24-8710
25-8706

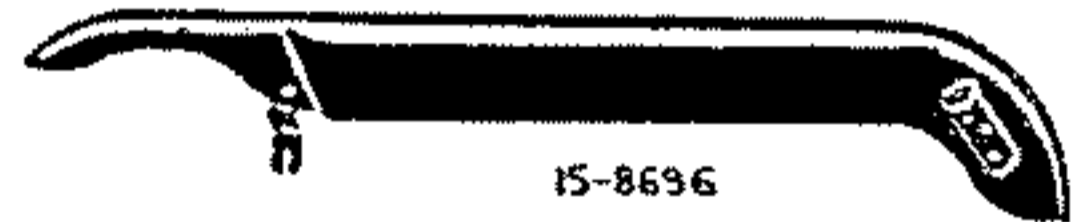

Back view of 15.8696

- 1927/28/29 Chainguards 27.8760 2.49 H.P.
Models S.29 etc 24.8707 4.93 H.P.
24.8710 4.93 H.P. De Lux
25.8706 7.70 H.P. Light V.Twin
With slight modification 15.8696 chainguard can be used
on the above machines. length 28 1/2 inches. 45.00 each



24-8824

- 127 Sloper, 500cc (part no. 24 8824), 1930-32 3.49 OHV
L30.11, 4.93 SV S30.9, 4.93 OHV S30.12, S30.13;
5.57 SV H30.10 44.00

REAR BRAKE CONTROL.

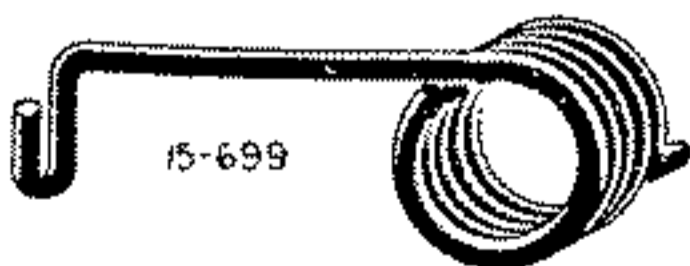

15-699

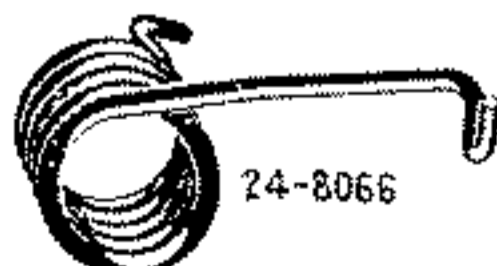

24-8066

1927/28 R/B Lever Spring 15.699
Fits 3.49 HP, SV, OHV & OHV Super. (4.93HP Standard)

24.8066 Fits 1927, 4.93 HP, OHV.

1929 (3.49 HP, SV) (3.49 HP, OHV Standard)
15.699 (4.93 HP & 5.57 PH Standard)
(4.93HP, OHV Light 2/Part) (7.70HP Light V.Twin)

1929 24.8066 (3.49 HP, OHV 2 Part Super)
(4.93 HP & 5.57 HP De Lux) (4.93 HP, OHV single & 2 part)

1930 24.8066 (3.49 OHV L30-11) (4.93 SV, S30-7, 5.57 SV H30-8)
(4.93 SV De Lux S30-9, 5.57 SV De Lux H30-10) (4.93 OHV S30-12)
(4.93 OHV De Lux S30-13)

1930 15.699 (4.93 SV Light S30-18) (4.93 OHV Light S30-19)
(7.70 V.Twin E30-14, 9.86 SV G30-15 V.Twin)

1931 24.8066 (4.93 HP SV S31-7) (5.57 SV De Lux H31-8) (4.93 OHV S31-10)
(4.93 OHV De Lux S31-10)

1931 15.699 (7.70 V.Twin SV E31-10)

1932-24.8066 (4.93 OHV De Lux S32-8) (5.57 SV De Lux H32-9)

15.699 & 24.8066 9.00 each

All prices + current VAT 16%

Alle Preise + versend gelten zzgl. MwSt.

Caracteristiques des
Motocyclettes

B.S.A

1931

B.S.A. KICK START SPRING
24.4266
FITS THE FOLLOWING YEARS & MODELS

- 1932 3.49SV, De Lux, L32-4
- 1932 3.490HV, De Lux, BS, L32-5
- 1932 4.930HV, De Lux, S32-8
- 1932 499 OHV, BS, W32-7



24-4266

CORNUCOPIA
INTERPRISES
DER GRUND 2
VAHLBRUCH

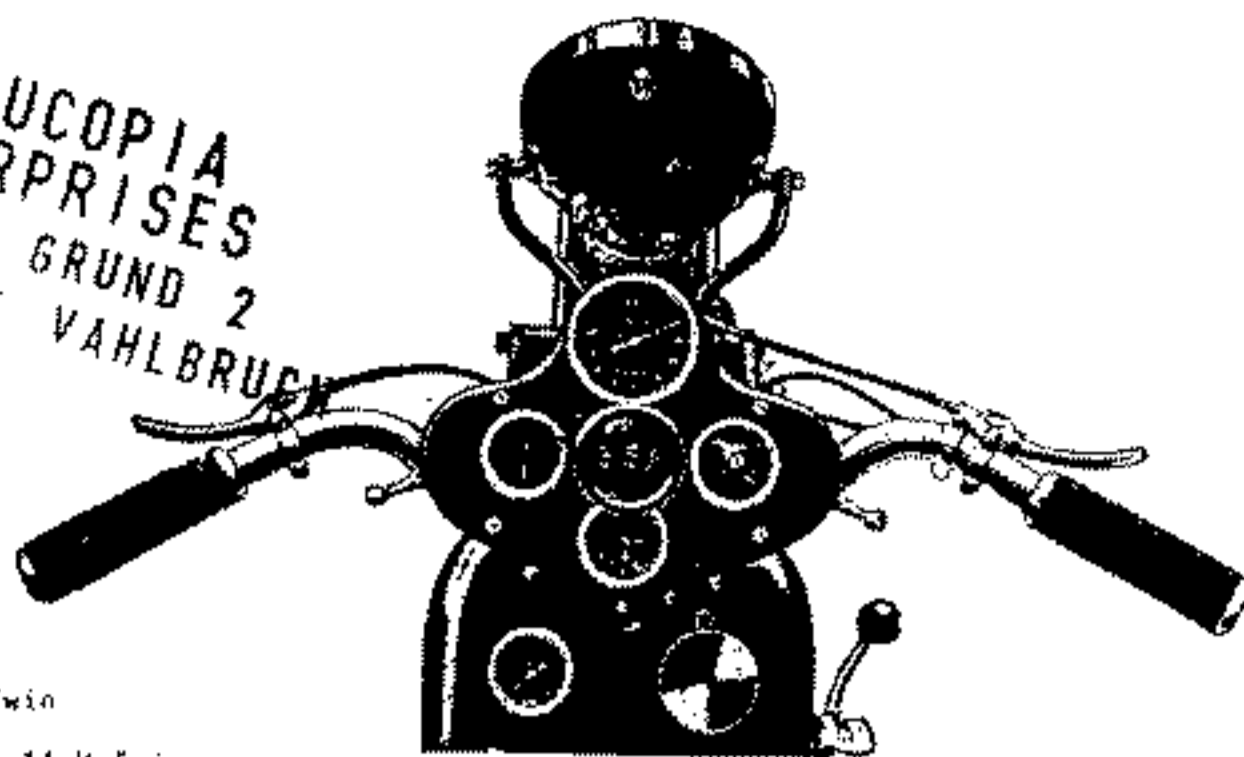

- 1932 499 SV, W32-6
- 1932 5.57 De Lux, H32-9
- 1933 All Models except B33-1-2, G33-13 V, Twin
- 1934 All Models except X340, B34-1-2, G34-14 V, Twin
- 1935 All Models except X35-0, B35-1-2

24.4266 Kick Start Spring £ 4-50

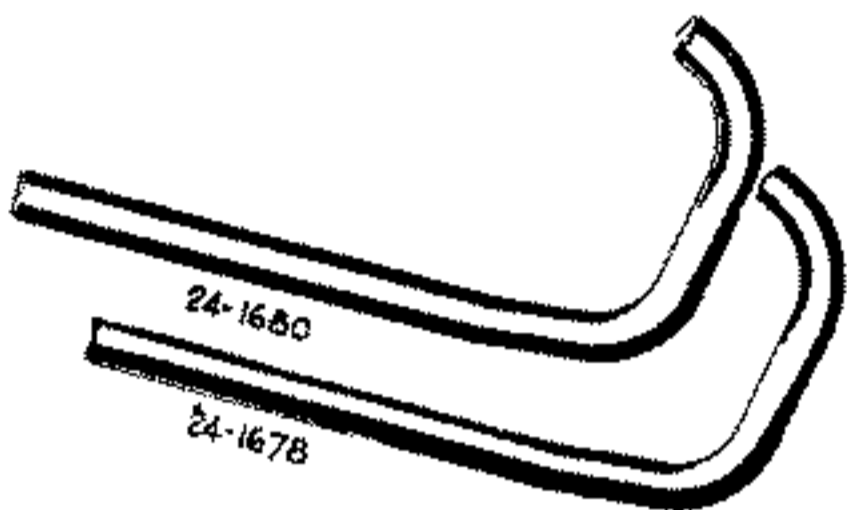

24.1653 24.1654

BSA replica unchromed ex. Pipes fit 1933 W33.9.4.990HV Special. Part No. 24.1653 & 24.1654

Fits 1934 & 1935 4.990HV Special, W34-10 & W35-9 Part No. 24.1678 & 14.1680

24.1678 & 14.1680 also fits W34-6 3.48 OHV £ 70-00

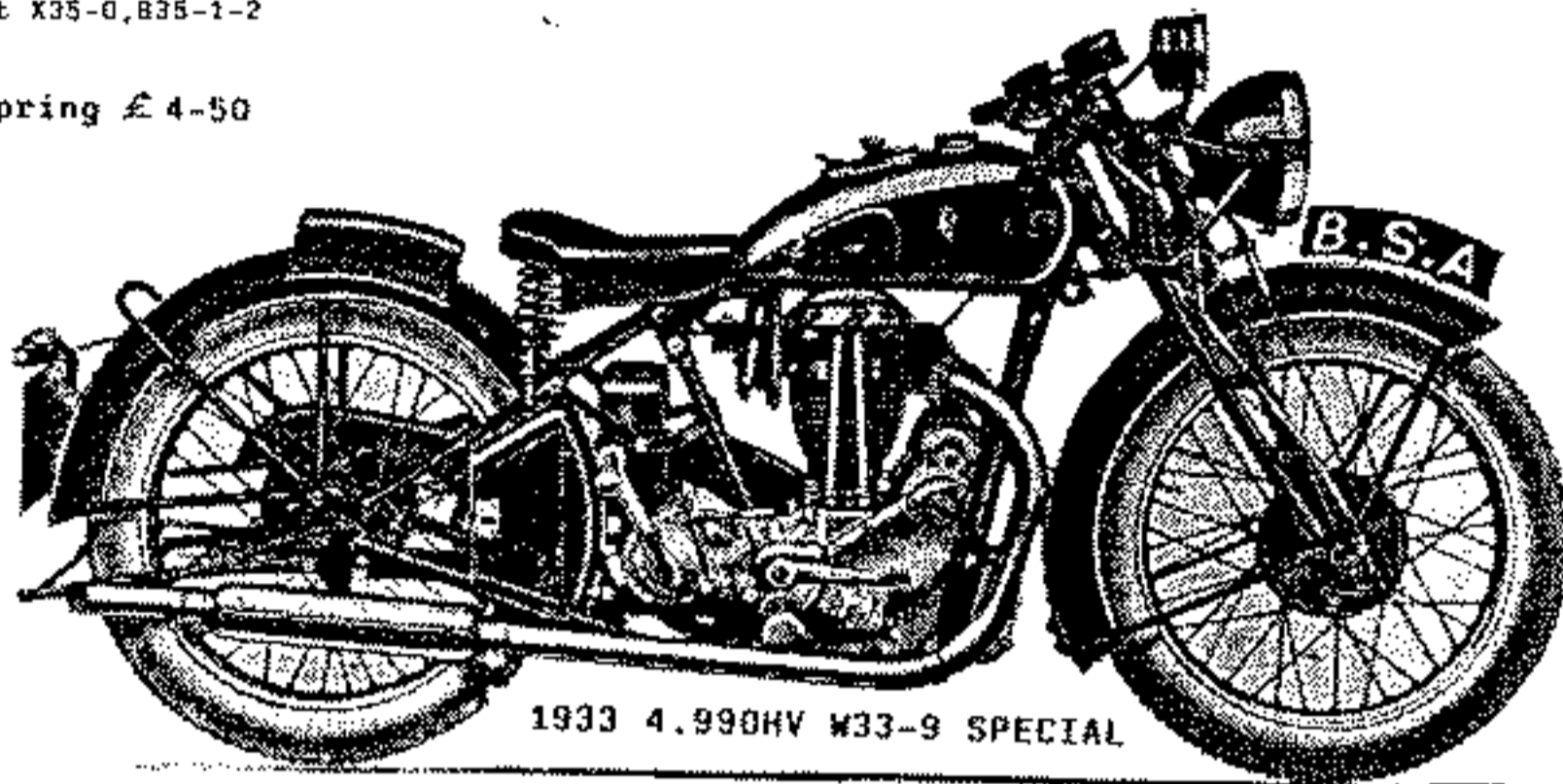

1933 4.990HV W33-9 SPECIAL

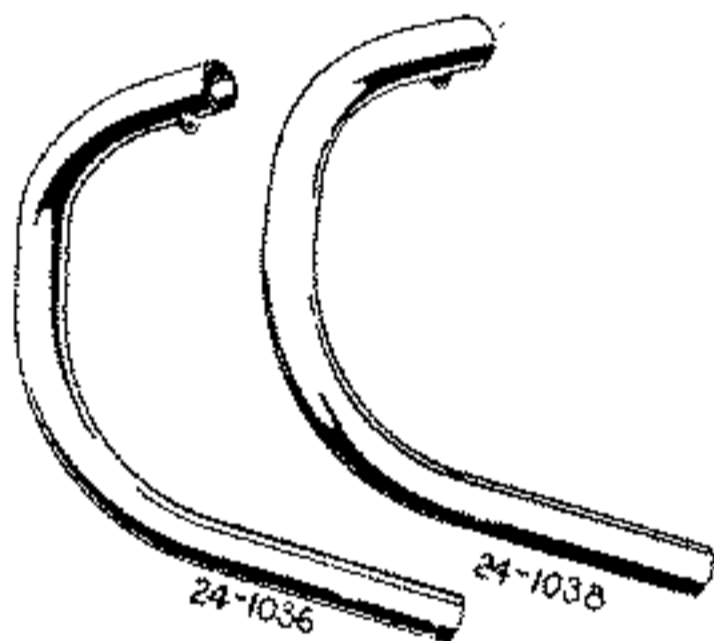

BSA replica unchromed Ex. Pipes
Right Hand Side 24.1036
Left Hand Side 24.1038
Fits model 1932 4.990HV W32.7
Twin Port £ 80-00 pair

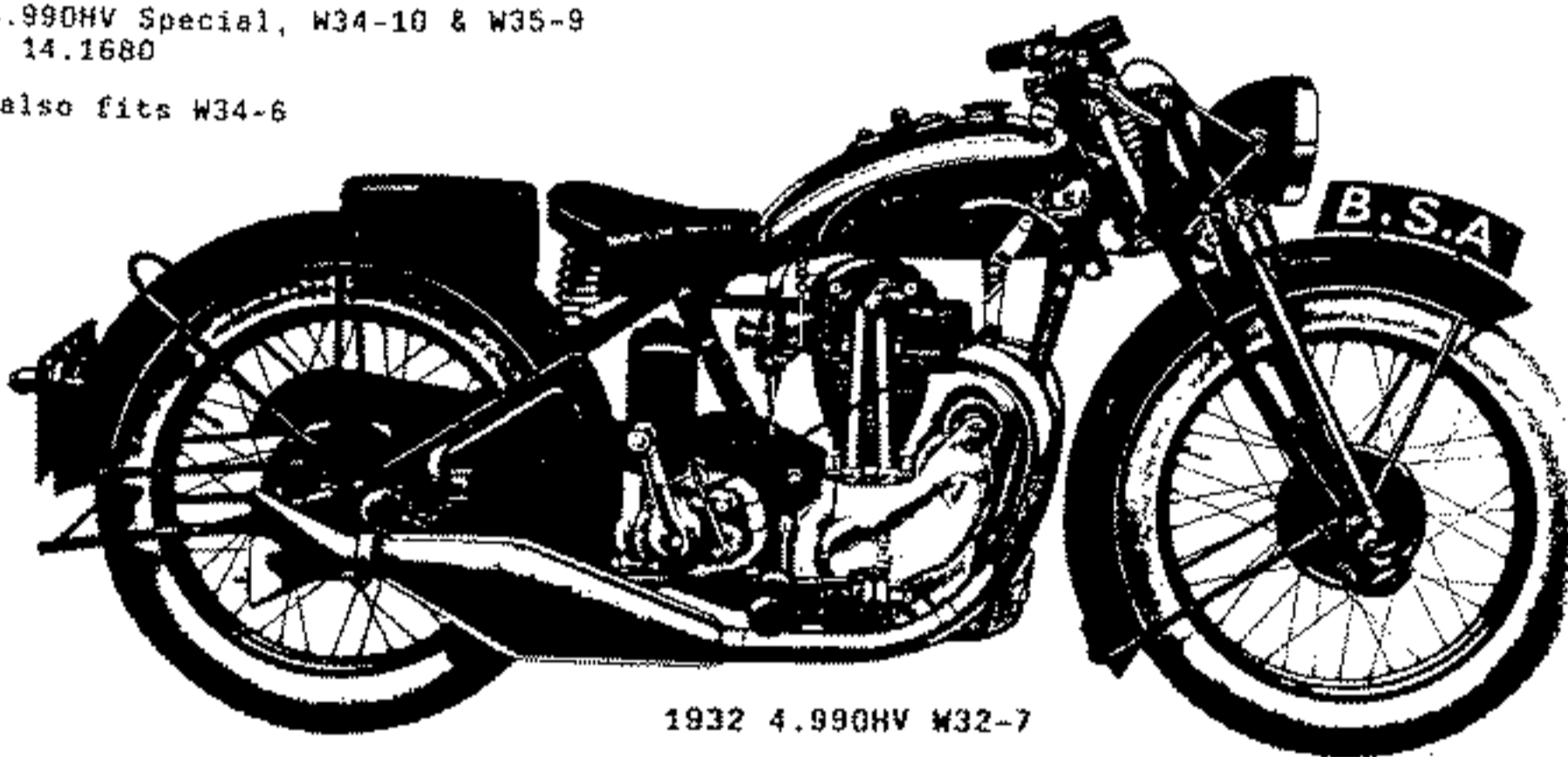

1932 4.990HV W32-7

BSA replica unchromed Ex. Pipes. Right Hand Side 15.2030
left Hand Side 15.2038. Only sold in pairs. Fits models
1931 3500HV L31-6 Twin Port, and 1932 3500HV L32-5 Twin
Port O.L.BS price per pair £ 68-00

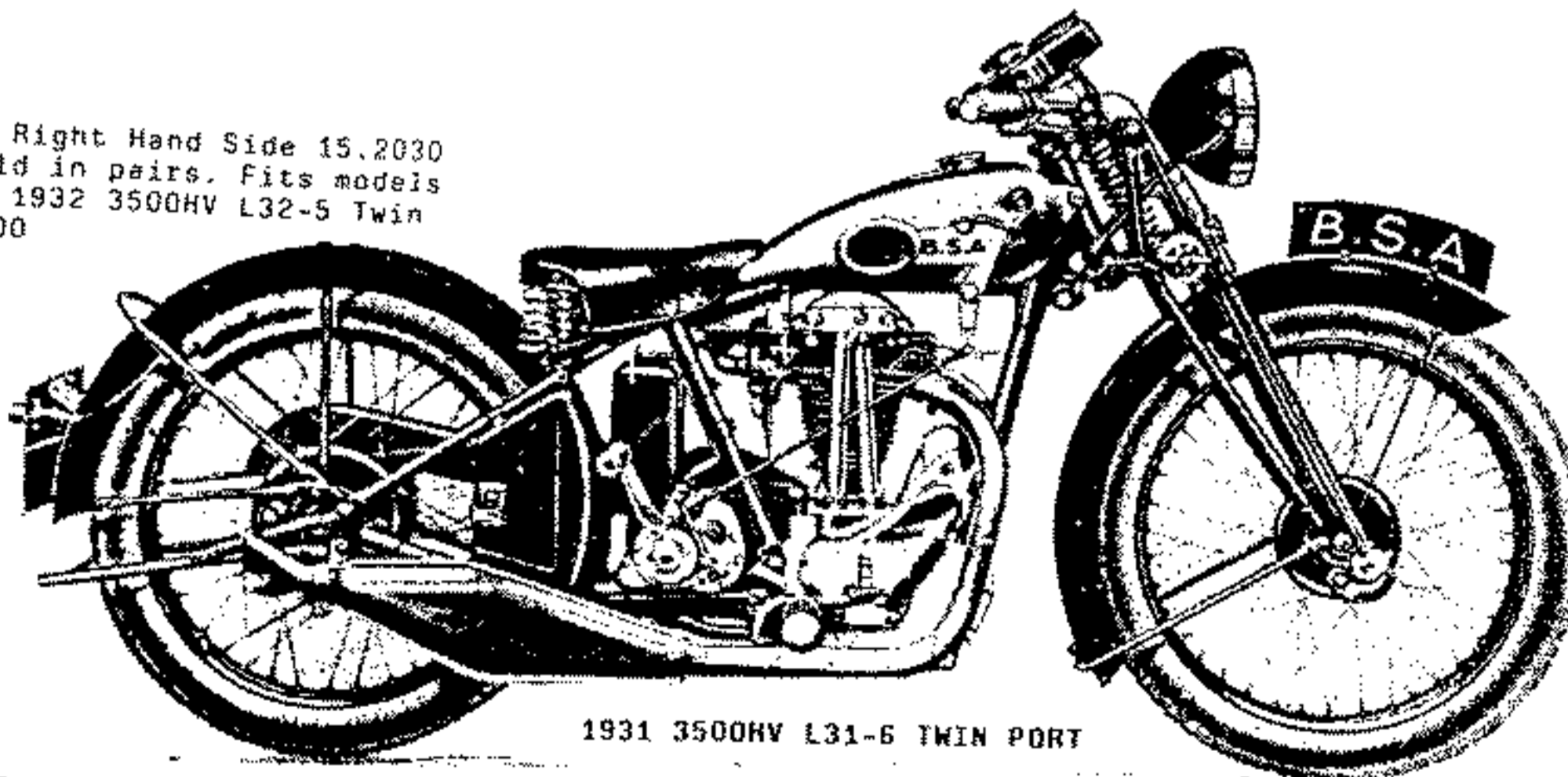
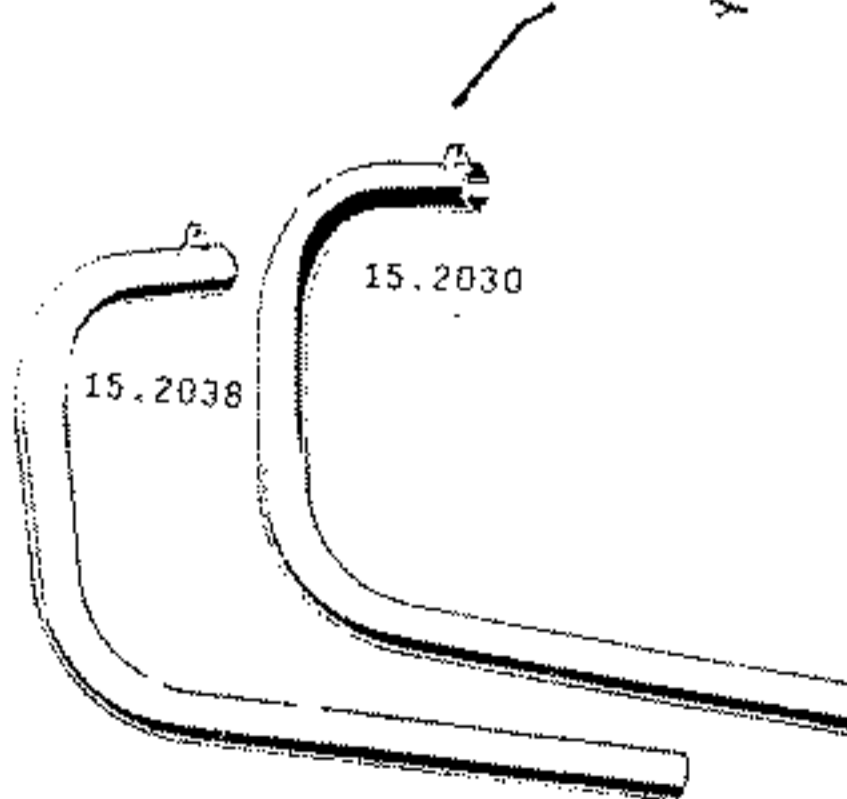

1931 3500HV L31-6 TWIN PORT

B.S.A. 4 CV. à culbuteurs de luxe. Modèle L31-6

All prices + postage + 16% VAT

Alle Preise + versand gelten zzgl. MwSt.

Vous ne pouvez pas vous tromper en choisissant une B.S.A.

W.D. M20 / M21 SPARES

all Replica Parts unpainted
alle Nachbauten sind unlackiert

Replica Field Stand W.D.

£ 65.00 Complete foreign made

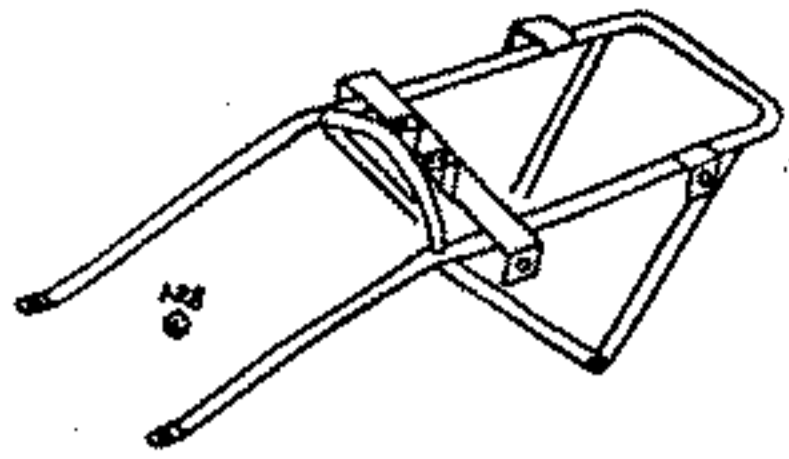

Replica W.D. Carrier as seen in Photo £ 48.00
(use with Pannier Carrier)

NUCOPIA
 ERPRISSES
 GRUND 2
 VAHLBRUCH

B.S.A.
means
CONSTANT
RELIABILITY

W.D. S1 Clip 12.00



Clip to hold Stand £ 12.00 (Replica)
on 1939-1940 Models without Pannier Frame's
fitted Clip fitted to lifting Stay (66-6947)

Clip zum fixieren des Ständers für Modelle der
Jahrgänge 1939-40 ohne Gepäckträgerstreben.
£ 12.00 (Nachbau)
Passender Clip für Hebe-Ständer (66-6947)

M20/S2 Stand Arm 26.00

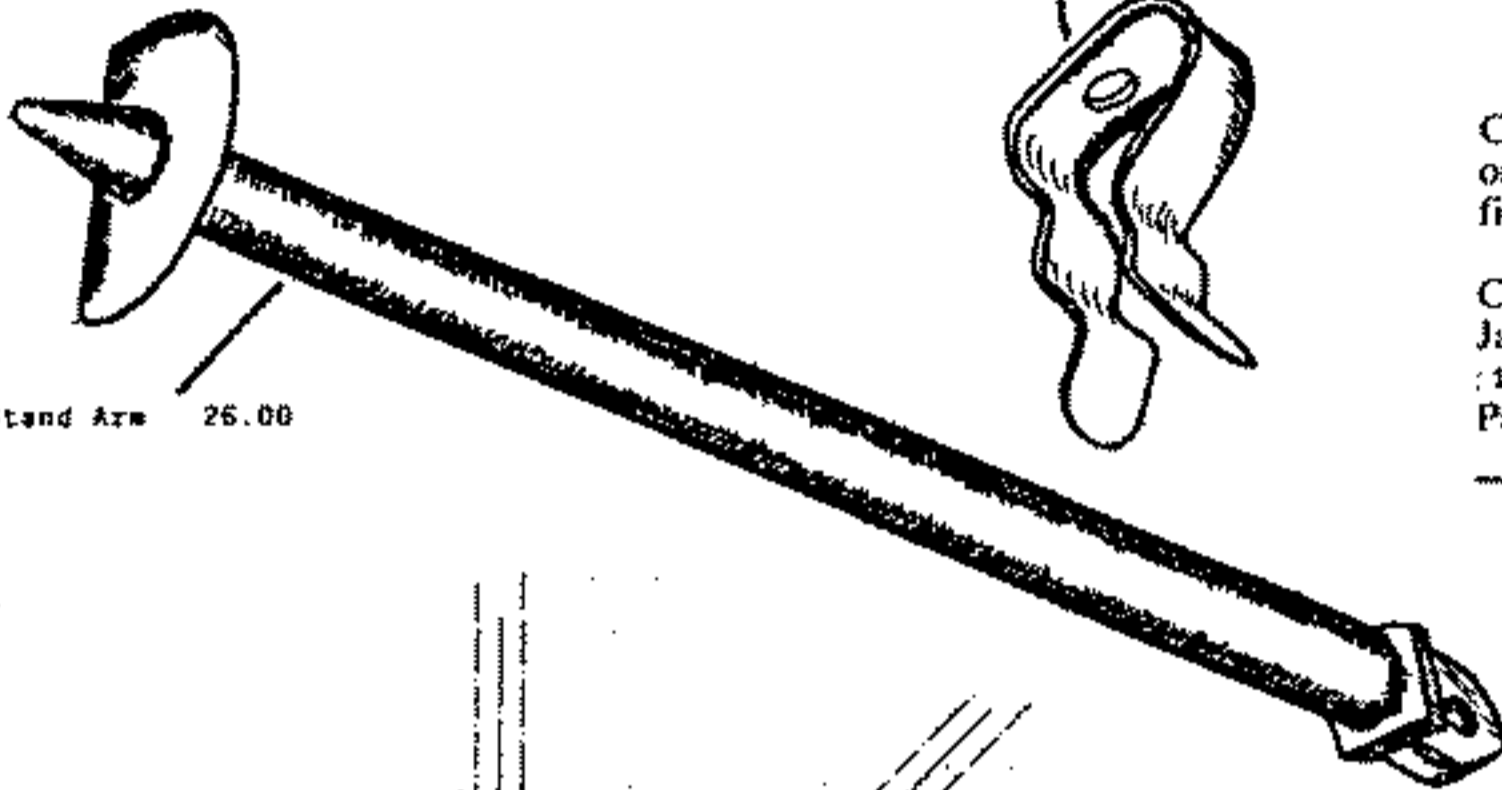

M20/S4 Swivel Joint Bolt 2.25



M20/S3 Stand Swivel Joint 25.00



DRAWINGS BY
N.R. BRIDWELL
GERMANY

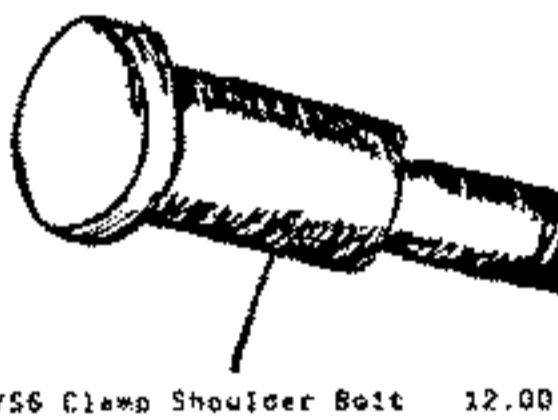

M20/S6 Clamp Shoulder Bolt 12.00

M20/S8 Bush 4.25



M20/S7 Spring £4-00



M20/S10 Clamp Bolt 2.25



M20/S9 Shoulder Nut & Washer 2.00



M20/S5 Frame Clamp 24.50

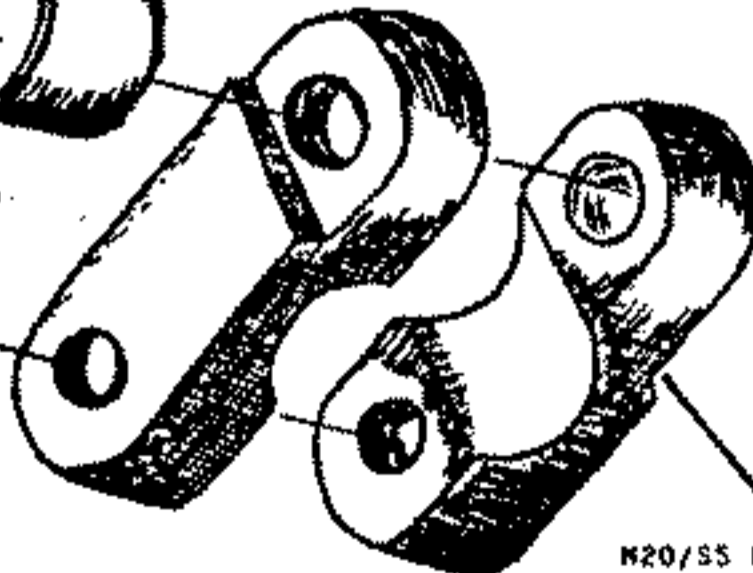

Primary Chain Case Inspection Cap Washer 27.207 fits C10/11 Girders & Teles
B31/32, M20/21 1946 & earlier £0.50 ea. genuine BSA



Primary Chain Case Screw 1.4606 (16 needed) C10/11 Girders & Teles B31/32
M20/21 1946+. Also fits Bottom Chain Guard (3 needed) £1.25 ea. genuine BSA



15-5816

B.S.A. 15.5816 Rear Brake Anchor Strap
M20/21.Replica. 12.00

B.S.A. 66.7029 Rear Brake Pedal Shaft (Bush)
Fits all models for 1937 except v.twins.
1937-39 same-B21,23,M22.
Rigid models 1946-53,M20,21,33. 3.50



66-7029

B.S.A. 66.7029 Rear Brake Pedal Shaft
M20,21.Fits all models for 1938,except-
v.twins.Replica.
1939 M22,B21,Rigid M20,21,33,1946-53. 7.00



66-7034

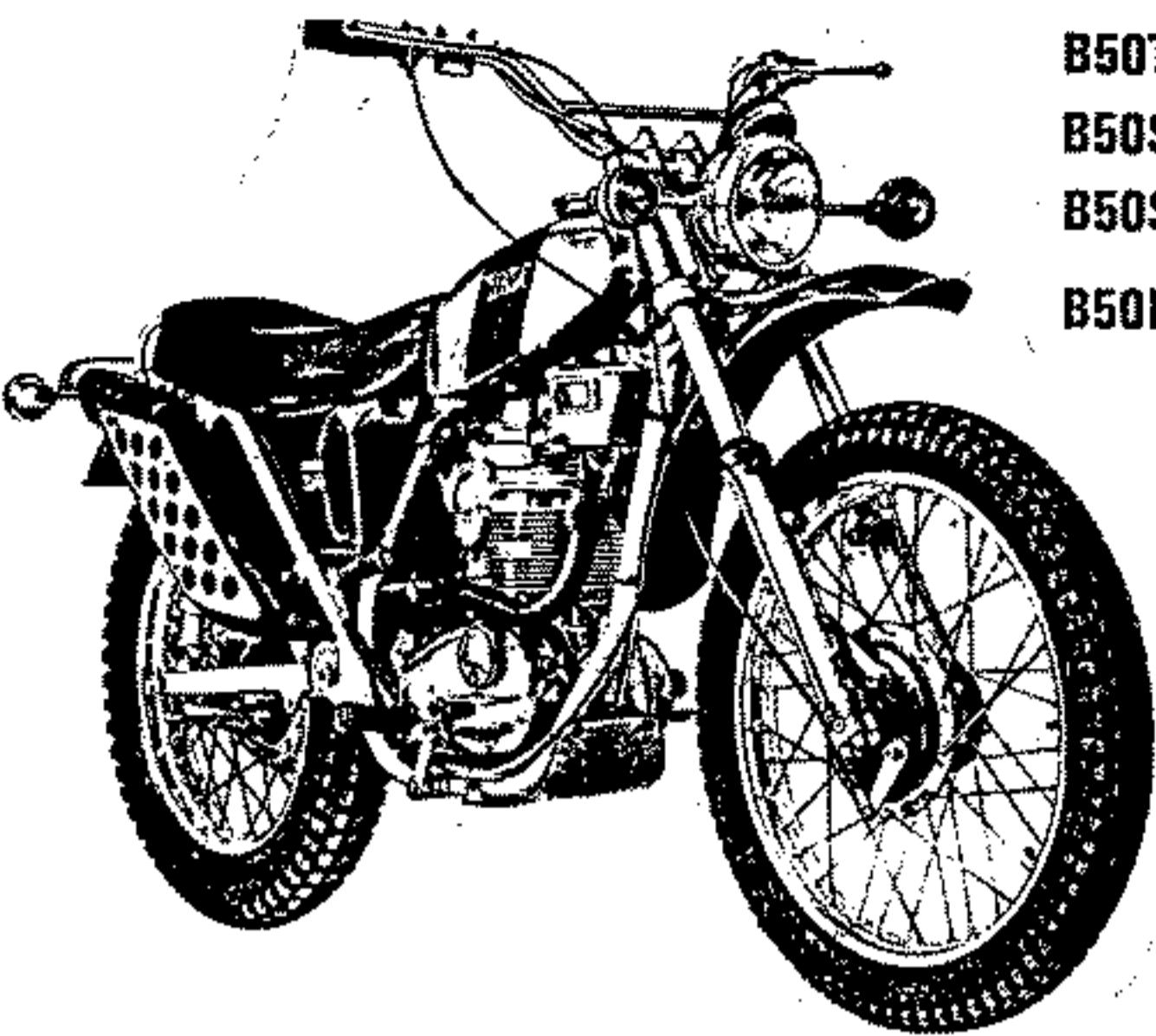

B50T Victor 500 Trail
B50SS Gold Star 500 Street Scrambler
B50SS Gold Star 500 Street Scrambler
(Home and General Export)
B50MX Victor 500 Moto-Cross

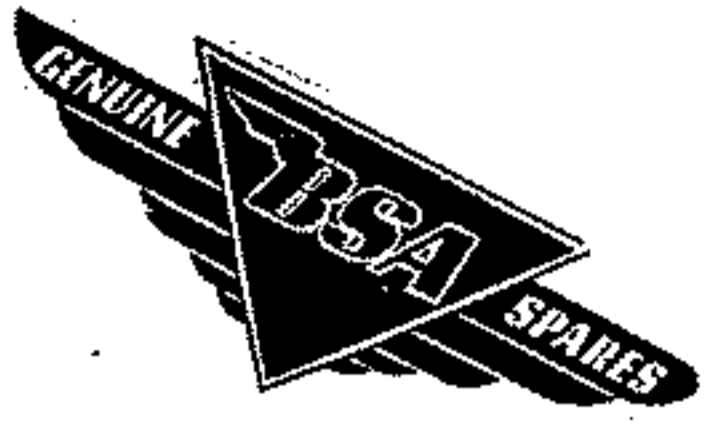

Model B25 Starfire

B44 Victor Special

C15 STAR

C15 SPORTS STAR

B.S.A. 41.3089 Mainshaft 1st Gear
 16 Teeth, B50.
 Also fits B44 1969 & 1970.

B.S.A. 41.3065 Mainshaft 1st Gear
 18 Teeth, B50.
 Victor 500 Motor Cross.

B.S.A. 57.3850 Cam Plate
 B50.
 Also fits B44 Shooting Star.

B.S.A. 41.3209 Clutch Spider
 B50.
 Also fits B44.

B.S.A. 57.4303 Clutch Chain Wheel
 B50.

Allen Screw Sets

B.S.A. Plated Allen Screw Sets
 For B50 Timing Cover, B50SS & T.
 Primary Chaincase

SCH22 Timing Cover to fit:-
 BSA C15, B40,
 1958-63

SCH23 Chaincase Side to fit:-
 BSA C15, B40, C25, B44.
 1958-68

SCH24 Timing Cover to fit:-
 BSA C15, B40, C25, B44.
 1964-68



B.S.A. 41.0569 Crankshaft Pinion
 C25, B25, B25SS Gold Star, Starfire B44, B50
 1968, 69, 70, 71, 72.

B.S.A. 40.3127 G/Box Mainshaft Spacer
 C25, B25, B25SS Gold Star, Starfire B44, B50
 1968, 69, 70, 71, 72.

B.S.A. 83.1972 Adjuster S.Arm Pivot
 B50, B50SS Gold Star Street Scrambler
 1971.

B.S.A. 71.2273 Outer Timing Cover
 B50.

24.00

26.00

B.S.A. 41.3045 Bush Mainshaft
 B50 (Two Needed)
 Also fits B44.1969 & 1970.

B.S.A. 65.2494 Outer Valve Springs
 B50. Genuine.

16.00

20.00

45.00

B.S.A. 71.1058 Primary Cover
 B50. Also 71.2932 & 71.2025.

B.S.A. 37.3750 R/Wheel Axel Distance Piece
 B50. (Speedometer Drive)

4.60
 4.50

4.75

6.00

5.60

SCH29 Timing Cover to fit:-
 BSA C25, B44,
 1969 onwards

SCH30 Chaincase Cover to fit:-
 BSA C25, B44,
 1969 onwards

16.00

B.S.A. 71.2513 Inlet & Exhaust Teppet
 C25, B25, B25SS Gold Star, Starfire B44, B50
 1968, 69, 70, 71, 72.

2.00



10.00

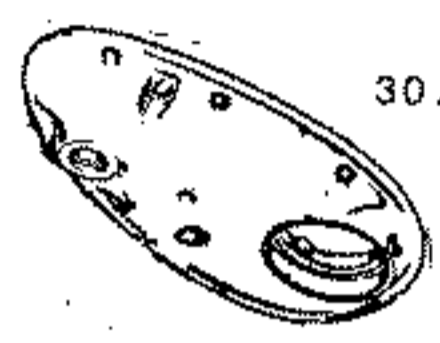

30.00



5.00 Eac.



3.00 Eact

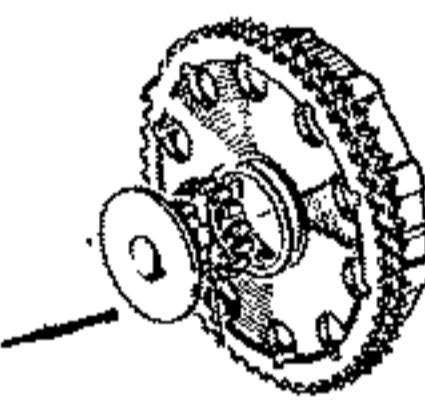

60.00

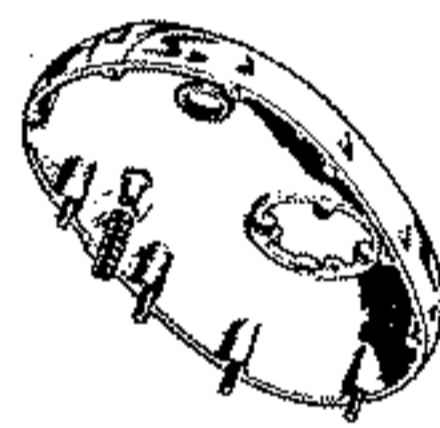

6.00

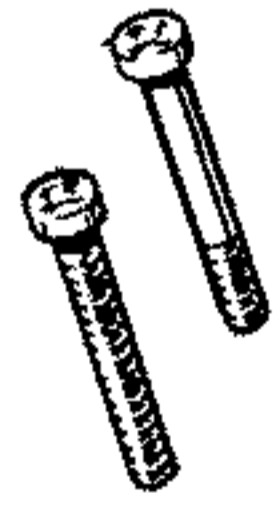
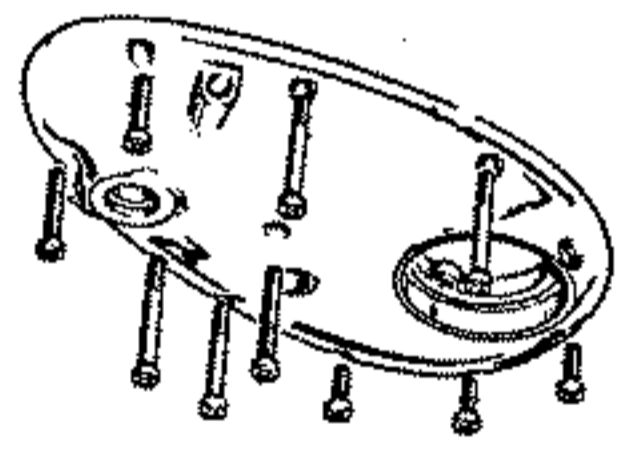

5.00

4.75



**CORNUCOPIA
 ENTERPRISES
 IN DER GRUND 2
 D-37667 VAHLBRUCH**

20.00 Each

B.S.A.

USA Groupe B 350 et 500 monocylindre

ENSEMBLE MOTEUR

Planches I, II, III

TYPES B 31 - B 32 - B33 - B 34 - B 32 GS - B 34 GS

All parts genuine B.S.A. unless stated

- B.S.A. 65.1137 Exhaust Lifter(used)
831,32,33,34.1946-56.Illustration no.14 2.00
- B.S.A. 65.1165 Exhaust Lifter Spindle(used)
831,32,33,34.1946-56.Illustration no.15. 6.00
- B.S.A. 65.387 Exhaust Lifter Bush(used)
831,32,33,34.1946-56.Illustration no.17. 8.00
- B.S.A. 66.1431 Exhaust Lifter Lever(used)
831,32,33,34.1946-56.Illustration no.21. 8.00
- B.S.A. 27.1163 Exhaust Lifter Cable Holder
2.443 & Nut.(used)
831,32,33,34.1946-56.Illustration no.23&24. 6.00

**CORNUCOPIA
ENTERPRISES
IN DER GRUND 2
B-37647 VAHLBRUCH**

First BSA to have a hydraulic telescopic front fork was the 1946 350 cc ohv Model B31, a type still regarded as one of Small Heath's 'best evers'. The machine shown is a 1953 model, for which plunger rear suspension was an optional extra.

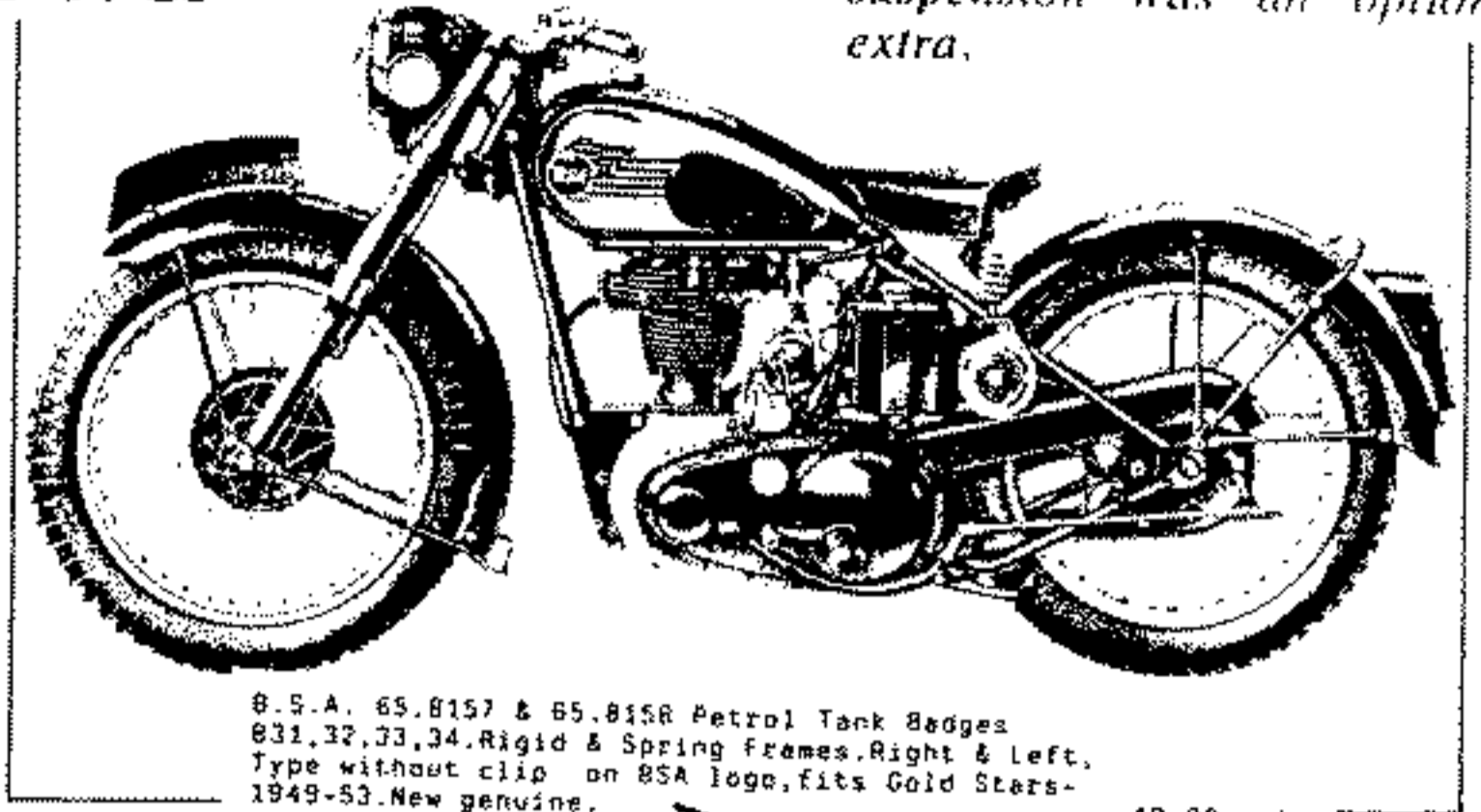

B.S.A. 65.8157 & 65.8158 Petrol Tank Badges
831,32,33,34.Rigid & Spring Frames.Right & Left.
Type without clip on BSA logo, fits Gold Stars-
1949-53.New genuine. 40.00 pair

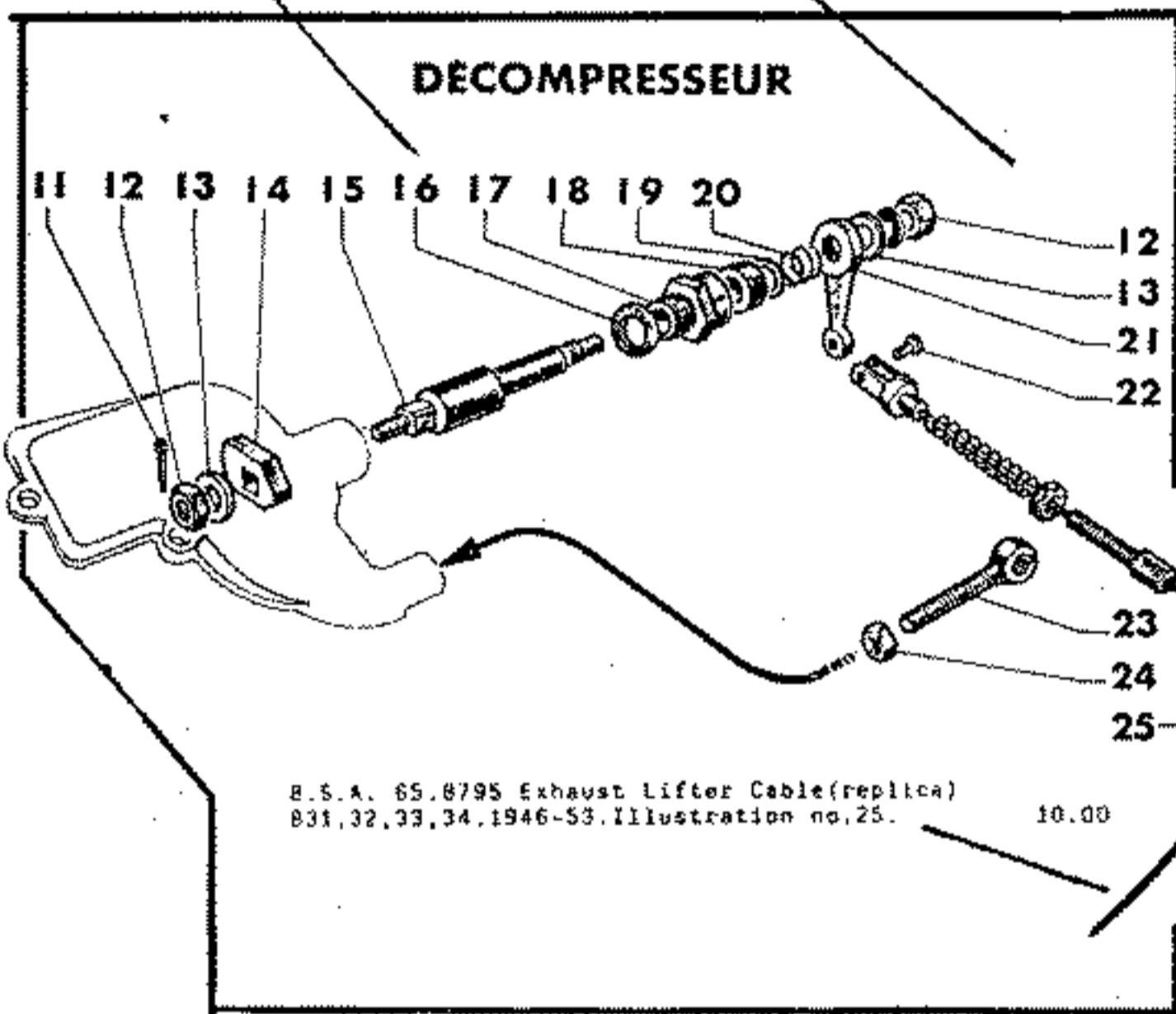

B.S.A. 65.8795 Exhaust Lifter Cable(replica)
831,32,33,34.1946-53.Illustration no.25. 10.00

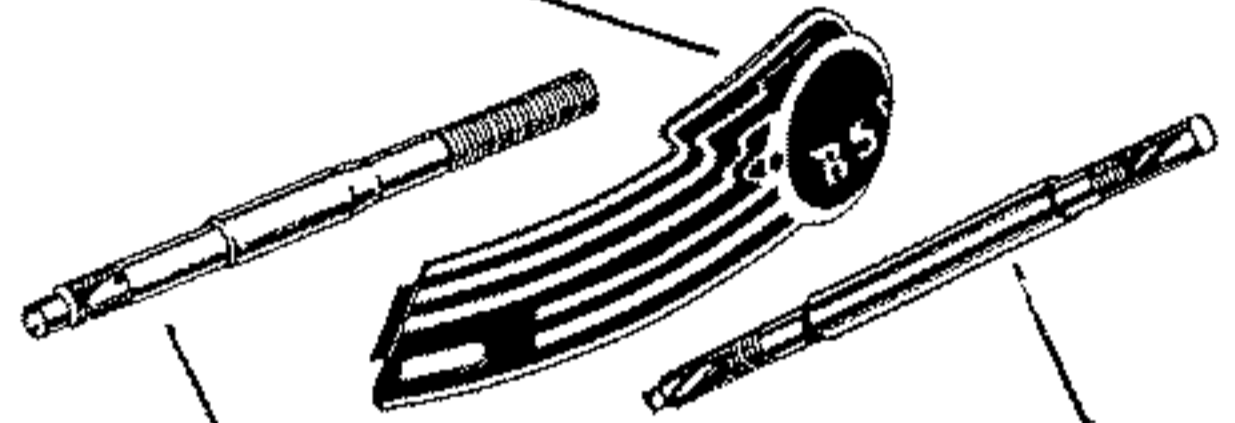

B.S.A. 65.6161 Rear Hub Spindle(new)
831,32,33,34.1946-52.Rigid Frame.Genuine. 20.00

B.S.A. 66.6265 Rear Hub Spindle(new)
M20,21,33.1949-53.Rigid Frame.Genuine. 20.00



B.S.A. 66.4647 Saddle Rear Fixing Stud
For Saddle springs.
831,32,33,34.1949-52.Also fits C10,10L.
Genuine. 3.00

B.S.A. 67.4040 Single Saddle Fixing Stud
831,32,33,34.Plunger.1946-53.Genuine. 3.00

Two nuts & washers to fit above 1.00

Allen Screw Set For Timing Cover SCH19 2.90

B.S.A. 1.4608 Primary Chaincase Screw set
831,32,33,34.1946-53.Set 16.Genuine. 6.00

B.S.A. Valve Covers(used)Exhaust 65.1160 18.00
Inlet 65.2159 12.00
831,32,33,34.1946-56.Illustration no.881

- B.S.A. 65.2352 Battery Carrier Swivel Block Plain Hole.
Genuine. 3.00
- B.S.A. 65.2353 Battery Carrier Swivel Block Tapped Hole.
Genuine.Illustration no.67. 3.00
- Replica 65.2352,65.2353 Stainless Steel.Longer than above.
With bolt 29.4661 & Strap saddle Washer Stainless 29.4662. 10.00 set
- B.S.A. 29.4661 Battery Carrier Strap Bolt.Replica,stainless. 3.00
- B.S.A. 29.4662 Strap Saddle Washer.Replica,stainless.
All above fit 831,32,33,34.Also group M-M20,21. 1.50

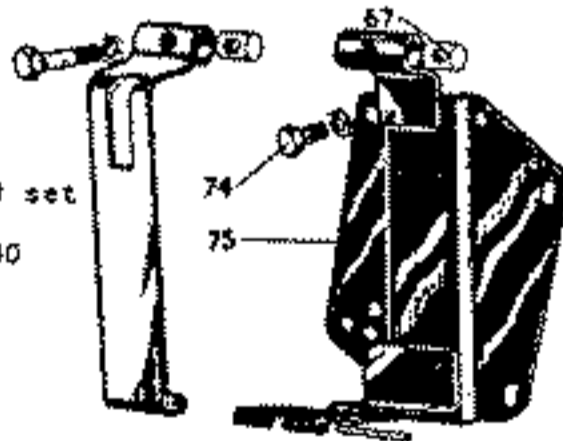

B.S.A. 29.4667 Chrome Battery Strap
C10,C11,831,32,33,34,A7,10.1946-53. 14.50

B.S.A. 65.4668 Battery Bracket(unpainted)
831,32,33,34.1946-53.Illustration no.8. 35.00

B.S.A. 65.1100 Exhaust Valve Rocker
65.1102 Inlet Valve Rocker
831,32,33,34.1946-61.Genuine.
Illustration no.587. 25.00 each

B.S.A. 15.645 Primary Chaincase Oil Drain
Plug.
C10,C11,831,32,33,34.M20,21.1946-53.Genuine. 2.00



65.4431 Gen BSA (used) 831/33
BSA 1946-53 Engine Plate Cover: Front
Rigid & Spring Frames £12.00

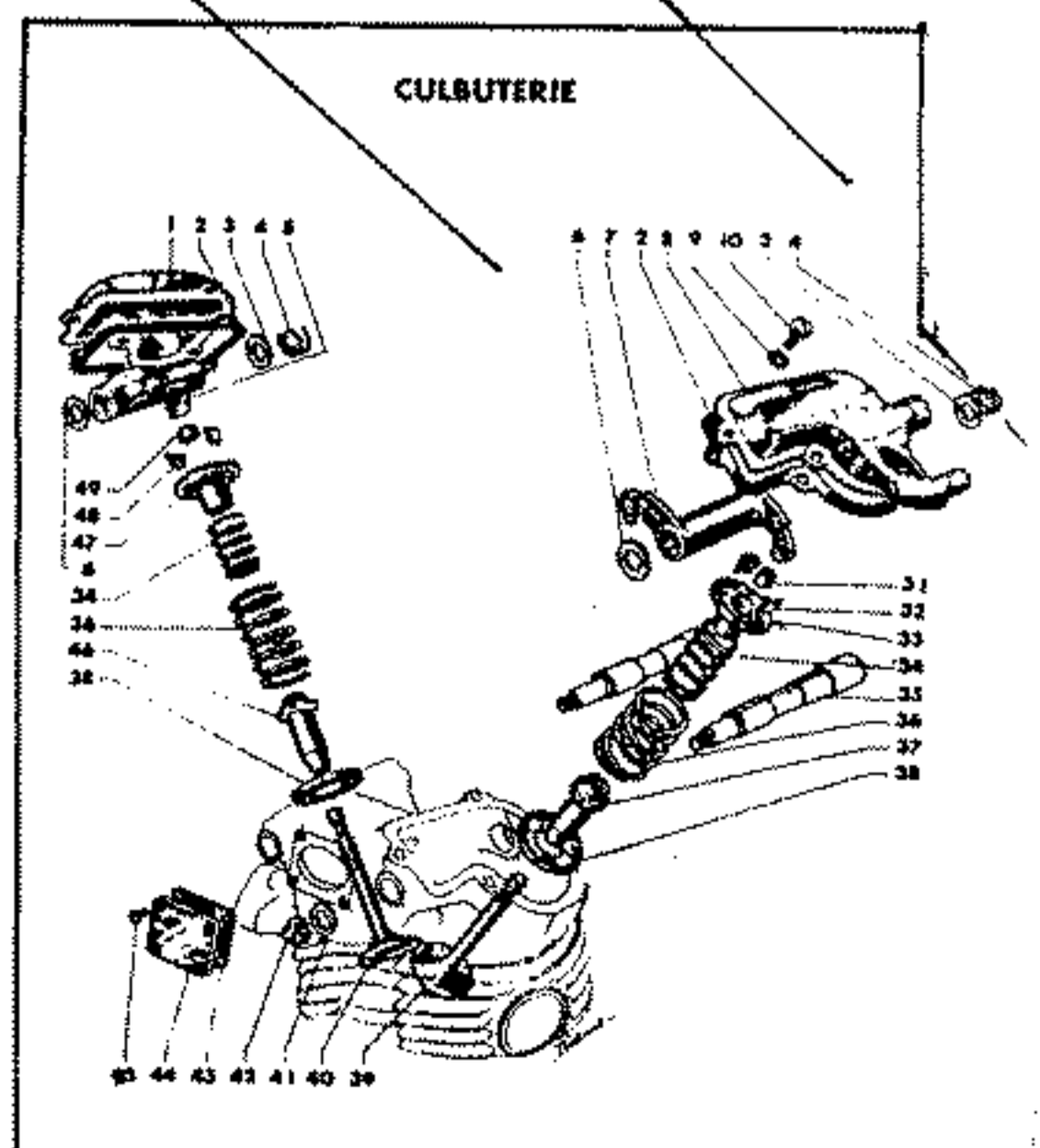

- B.S.A. 65.1513 Inlet Valve Guide.831,32. 5.50
- 65.1515 Inlet Valve Guide.833,34. 5.50
- 65.1514 Ex.Valve Guide 831,32 5.50
- 65.1516 Ex.Valve Guide 833,34 5.50

B.S.A. 65.311 Valve Rocker Spindle Nut
831,32,33,34.1946-61.Illustration no.42 2.00 each

CORNUCOPIA
ENTERPRISES
IM DER GRUND 2
37647 VAHLBRUCH

Gearbox

"B" Group and Gold Star
(Clubman's) 350 c.c. and 500 c.c.



There's over 90 years reputation
for Quality behind the B.S.A.
trade marks which are your
safeguard.

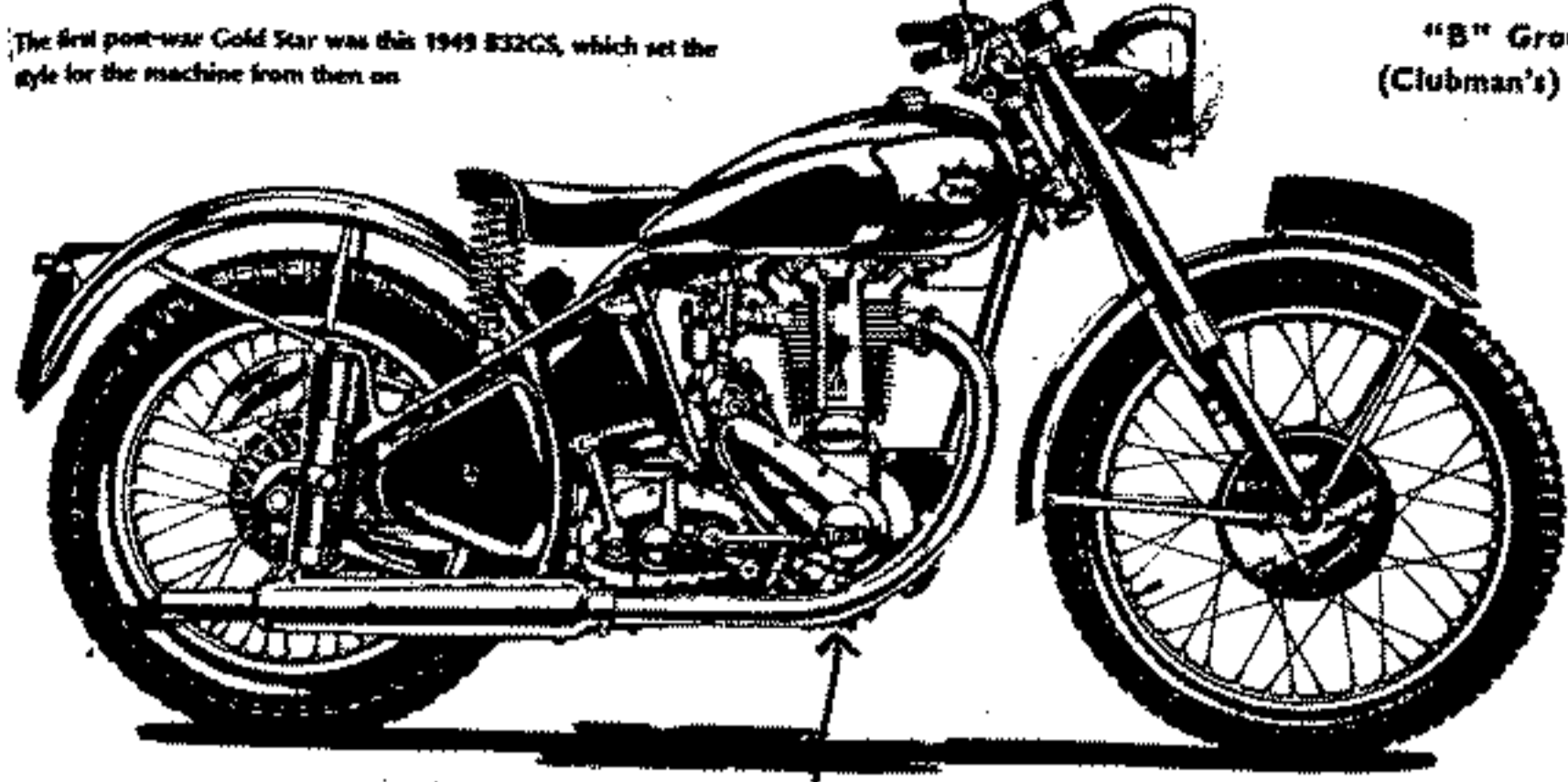

The first post-war Gold Star was this 1949 B32GS, which set the style for the machine from then on

27-4063

- 27.4063 G.Box Sprocket Nut Lock Washer
Fits 1929 2.48 K.P. De lux
- 1930 B30-3 & 4 250cc,350cc,L30-5 & 6
- 1931 250cc S.V. B31-1 & 2.250cc O.H.V. B31-350cc S.V. L31-4
- 1932 250cc O.H.V. B32-1.350cc S.V. L32-2
- 1933 250cc S.V. B33-1.250cc O.H.V. B33-2
- 1934 150cc x 34-0.250cc S.V. B34-1-2
- 1935 150cc O.H.V. x 35-0.250cc S.V. B35-1-2.
- 1936 150cc x 0.250cc S.V. B1-2
- 1939 C10,C11 1940 C10,C11,C12 1946 C10,C11 1947 C10,C11
- 1948 C10,C11 1949 C10,C11 1950,51 C10,C11 3 speed
- 1952,53,54,55,56,57 C10L,C11G 3 speed 2.25 each

29-3836

- 29.3836 G Box Sprocket Nut Lock washer
- 1946 B31,32 1947 B31,32,33,34 1948 B31,32,33,34
- 1939 B21,23,24,25,26 1940 B29 2.25 Each



29-3836
27-4063

B.S.A. 24.4393 Gearbox Dog Clutch
B31,32,33,34.Fits plunger & rigid models.
Two needed.Genuine.



16.00 each **65-3492**

B.S.A. 65.3492 Mainshaft Second Gear
21 Teeth.1947,48.Fits B31,32,33,34.
1946 B31,32.Genuine. 28.00



29-9132

B.S.A. 29.9132 Toolbox Fixing Screw
A7,A10,rigid & plunger models.Fits-
C10,C11,B31,32,34,M20,21.1950-54. 8.00



89-4311

B.S.A. 89.4311 Toolbox Fixing Screw (Circlip)
To fit above models. 1.00

B31/33/34 Rigid,Plunger & S.Arm Ex. Pipe unchromed £32.00,
chrome £45.00 replica



65-7720

B.S.A. 65.7720 Sprung Plunger Frame
B31,32,33,34,unpainted. Replica 46.00



65-7715

B.S.A. 65.7715 Rigid Frame Chainguard
B31,33,1949-53,unpainted. (Replica Part) 40.00



B.S.A. 65.3435 Mainshaft Gear
22 & 18 Teeth.1950,51,52,53.
Scrambles & Grass Track,350cc.
500cc Gold Star,Plunger,G.Box
B.S.A. 66.3220 Layshaft Gear
Close ratio,19 & 20 teeth,Plunger,rigid,
Gold Star Clubmans 350cc,500cc.1949-53. 60.00

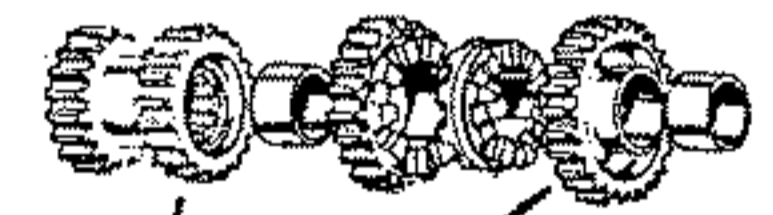

B.S.A. 65.3441 Layshaft Gear with Bush
Close ratio,26 teeth.Plunger,rigid,Gold star
clubmans,350cc,500cc.1949-53. 60.00

B.S.A. 66.3220 Layshaft Gear
Close ratio,19 & 20 teeth.Plunger,rigid,
Gold Star Clubmans 350cc,500cc.1949-53. 60.00

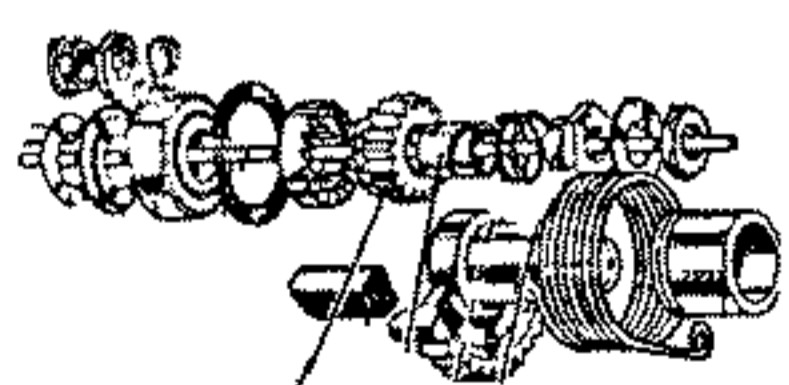

B.S.A. 65.3283 Kickstart Pinion 17 Teeth
B31,32,33,34,1946,47,48.Genuine. 20.00

B.S.A. 65.3173 Pinion Sleeve With Bush
B31,32,1946,B31,32,33,34,1947,48,49.
Genuine. 45.00

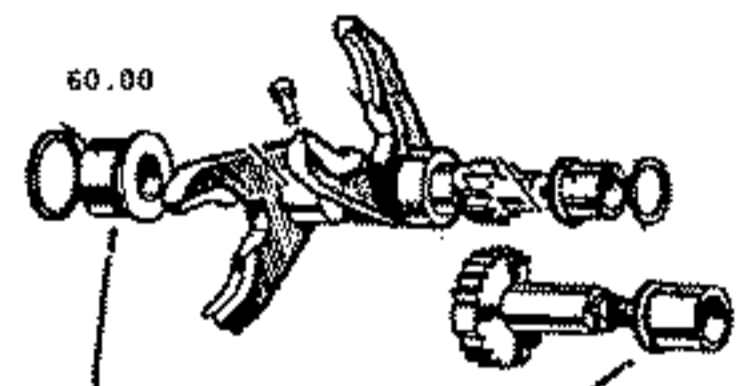

B.S.A. 24.4248 Gear Control Quad Bush
M20,21,33,B31,32,33 Gold Star.1949-53.
Genuine. 7.00

B.S.A. 24.4245 Control Shaft Bush,Inner Cover
M20,21,33,B31,32,33,34,Gold Star.1949-53
Genuine. 20.00



65-3173

B.S.A. 66.1511 Inlet & Ex. Tappet Head
B31,32.Two needed.genuine BSA. 6.00 each

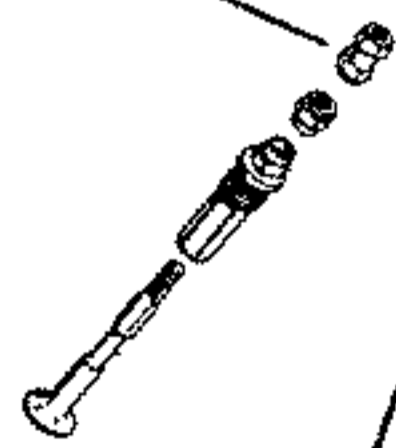

7.00



24-724
24-722

8.00



65-2045

B.S.A. 65.2045 Crankshaft Bell Bearing(Drive Side)
B31,32,33,34.Early Gold Star.One needed. 8.00

B.S.A. 24.724 Crankshaft Roller Bearing(Drive Side)
B31,32,33,34.Early Gold Star.One needed. 28.15

B.S.A. 24.722 Crankshaft Roller Bearing(Fiming Side)
B31,32,33,34.Early Gold Star.One needed. 32.00

B.S.A. 65.1388 Crankshaft Roller Bearing(Drive Side)
B31,32,34.S.Arm Gold Stars 1954-63. 38.00

Sollten Sie etwas suchen was nicht abgebildet ist,fragen Sie bitte
bei uns nach.

350 B32 Gold Star

500 B34 Gold Star

COMMUNICOPIA
 REPRISSES
 HILF GRUND 2
 FAHLBRUCH

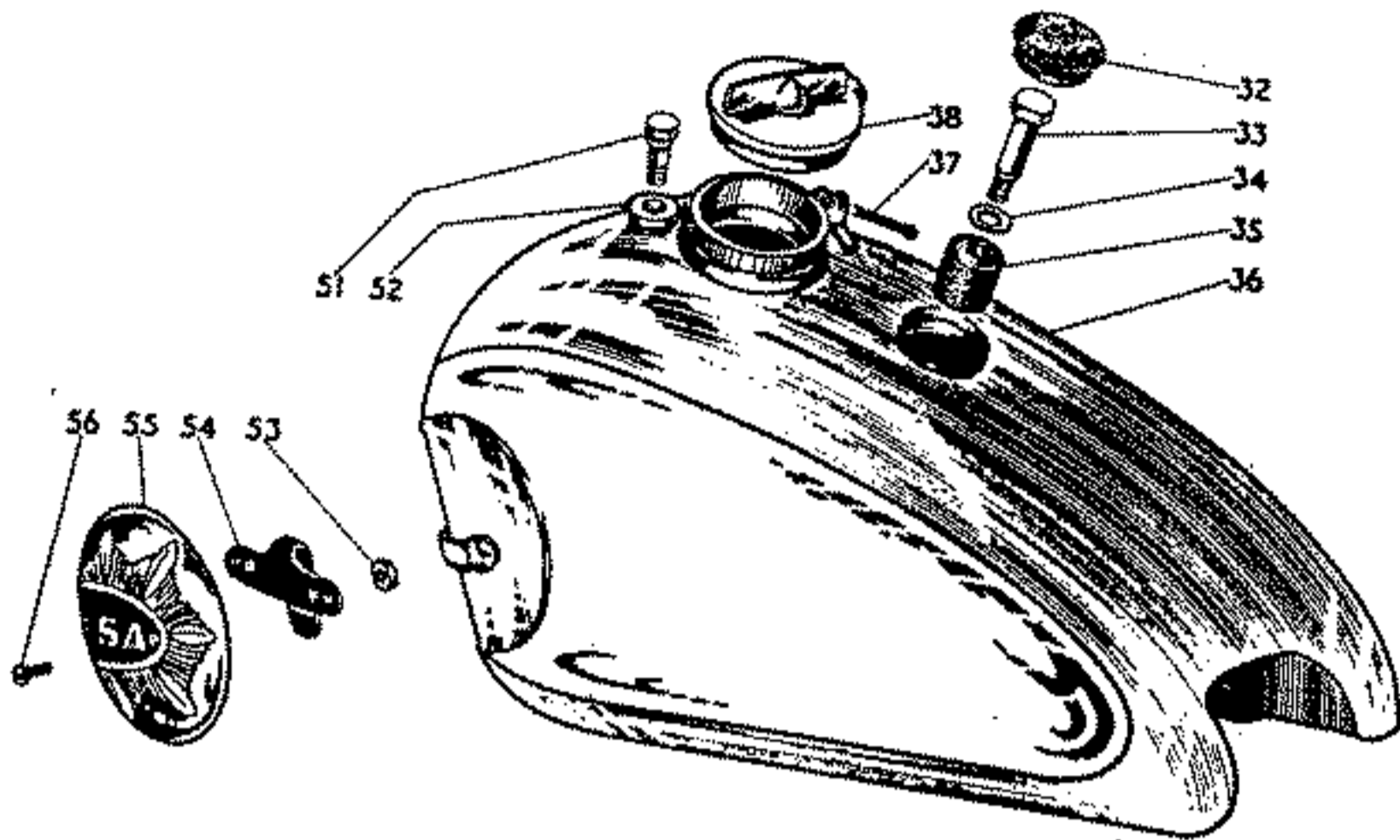
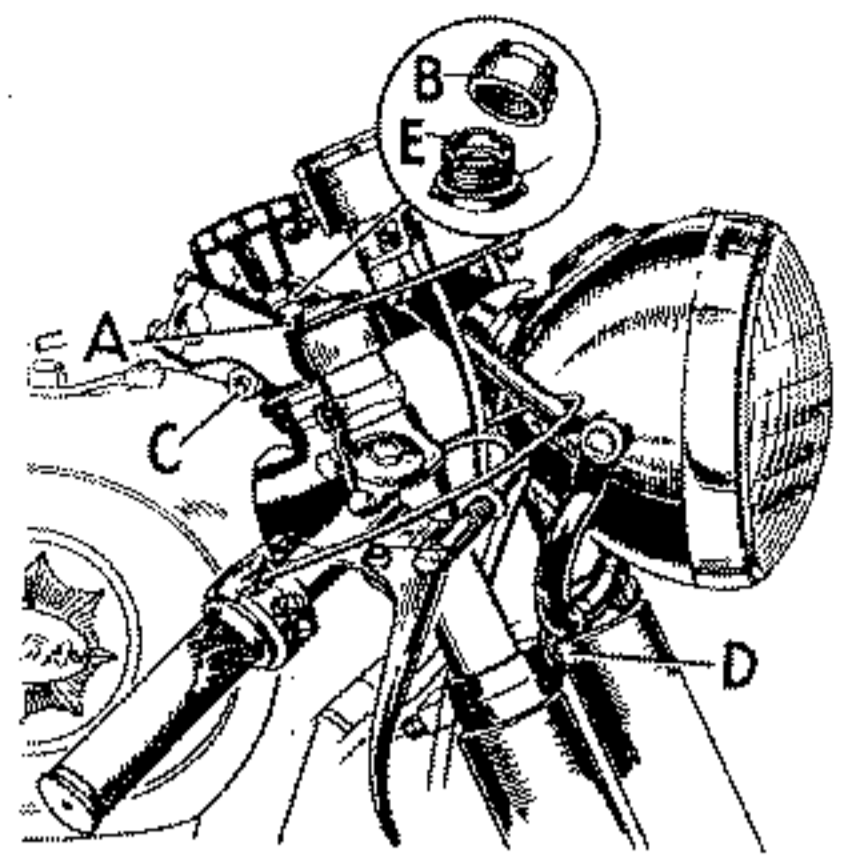

- B.S.A. 65.8193 Petrol Tank Badges (pair)
 DB, DBD 32 & 34 500cc Gold Star. Also Rocket
 Gold Star. 1955-63. S. Arm models. 38.00
- B.S.A. 42.8020 Petrol Tank Badge Clips
 To fit above. (pair). 12.00
- B.S.A. 65.8317 & 42.8034 Badge-To-Clip fixing
 screw & nut. To fit above Clip. 1.00 each
 4.00 set (4)
- B.S.A. 42.8107 Petrol Tank (steel) unchromed
 Less badges, petrol cap etc. Replica, four gallon.
 350cc, 500cc, Gold Star DBD 32, 34. 500.00
- B.S.A. 42.8107 Petrol Tank (Nickel copper, chrome plated)
 Less badges, petrol cap etc. Replica, four gallon.
 350cc, 500cc, Gold Star DBD 32, 34. 700.00

BSA Gold Star Rear
 No. Plate 42.8351 to
 fit Clubman M. guard
 350/500cc, DBD 32/34
 with or without
 reflector section
 unpainted £44-00

57 58 59 60 61 62

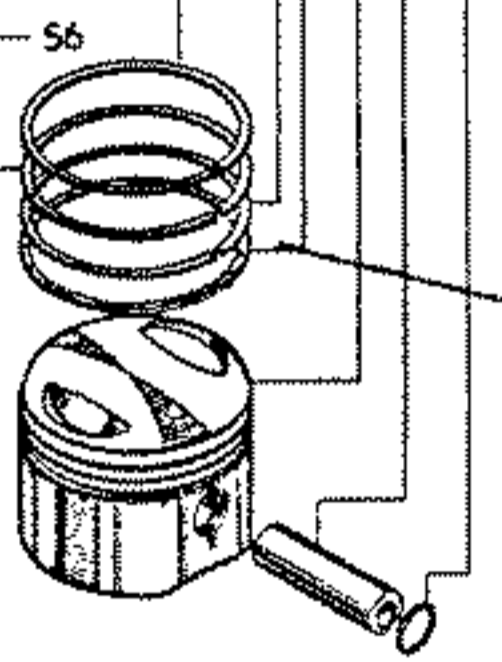

- B.S.A. 89.5061 Clubmans Fork Tubes
 Hardened chrome plated. Replica.
 Gold Star, 350cc, 500cc, DBD 32, 34,
 B31, 32, 33, A7, 10. 70.00 pair
- 1939-50 B34 Gold Star Piston Rings. Genuine BSA.
 STD size 18.00 set. Single rings 6.00 each

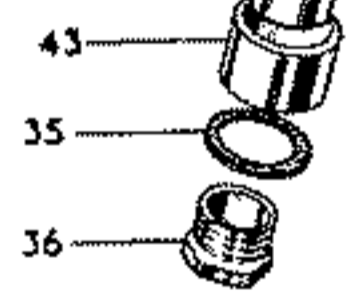

- B.S.A. 89.5036 Fork Springs (solo)
 A7, A10, also fits 350cc, 500cc,
 DBD 32/34 Gold Stars etc. 1950-63.
 And S. Arm models 20.00 pair

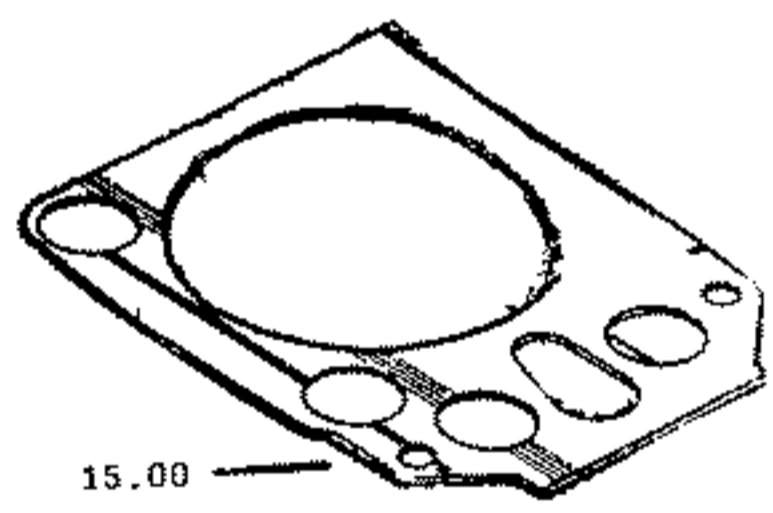

- B.S.A. 65.1653 Cylinder Base Shim ("064")
 Gold Star D.B.D 34 500cc (Genuine BSA)

- B.S.A. 29.5313 Chrome Oil Seal Holder
 Gold Star. 30.00 per pair



- B.S.A. 42.3412 Rear Footrest Hanger Bracket
 Gold Star (with S. Arm, DBD 32, 34,
 only for Clubman M. set footrests).
 Genuine BSA. Limited stocks. 30.00 pair

- B.S.A. Gold Star Valves. Genuine. Limited stocks
- 1949-54 500cc Inlet Gold Star 65.1632 (Fitted up to E.No. 2834A-263)
- 1952-54 500cc Exhaust Gold Star 65.1633 (Fitted up to E.No. 2834A-263)
- 1953-57 350cc Inlet Gold Star 65.1630
- 1949-52 500cc Inlet Gold Star 65.1352

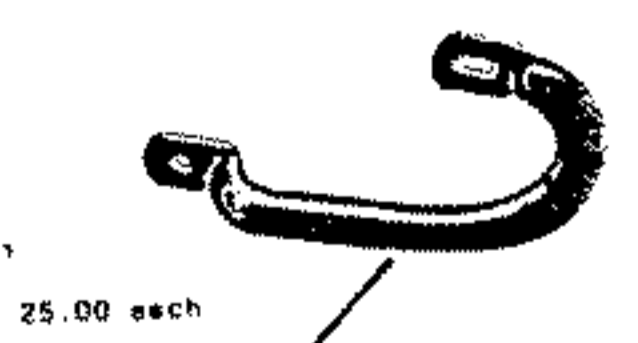

- BSA B31/33/34 late Lifting Handle (can be fitted to Gold Star, Rocket Gold Star) unpainted £10.00 replica

- Swivel Pin (plain hole) 42.4505 } Stainless Steel
- Swivel Pin (tapped hole) 42.4506 }
- Battery Strap Bolt 24.7343 x 2
- Pin & Bolt Set £7.00 + VAT
- Two sets needed per Battery Strap

- Battery Strap (top) 42.4502 / 8.00 + VAT
- Battery Strap (side) 42.4503 / 8.00 + VAT
- Battery strap (side) complete 42.4516 / 8.00 + VAT
- A7/A10 1954-63 Stainless steel

Fits all Swinging Arm Gold Star
 models. 350cc, 500cc and Rocket
 Gold Star 1954-63. B31/32/33/34
 Swinging Arm models.

- B.S.A. 67.3302 Mainshaft Sliding Gear
 A7 A10 Spitfire Scrambler, Gold Star
 500cc DBD.34 19T (Genuine BSA) 48.00

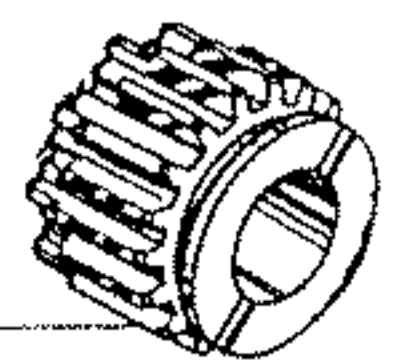

67-3302

GOLD STAR MODELS 350 c.c., 500 c.c.



**CORNUCOPIA
ENTERPRISES
IN DER GRUND 2
D-37647 VAHLBRUCH**

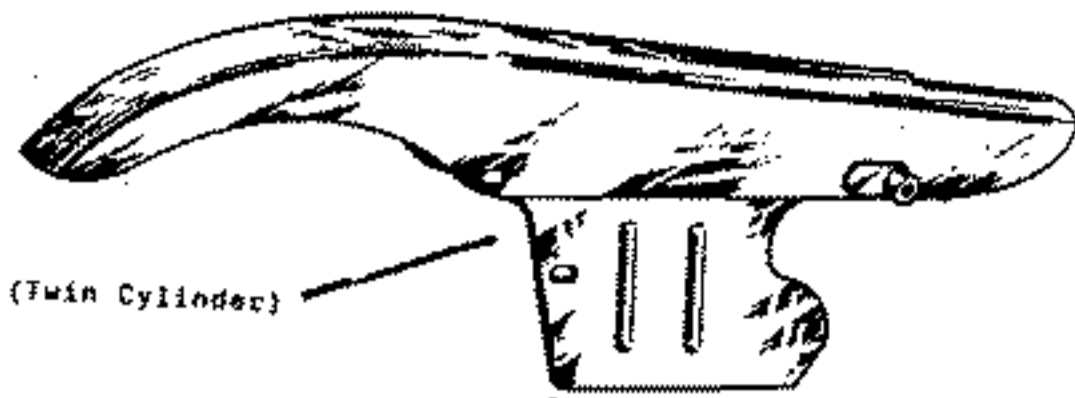

BSA Gold Star DBD 32/34 (Single), Rocket Gold Star (Twin Cylinder)
S.Arm Models Chrome £68-00. Unchromed £48-00

B.S.A. 42.6759 & 42.6785 Rear Mudguard Fixing Clips
Gold Star DBD 32/34, Clubmans replica.
Illustration no.93 & 106.

3.80 each

B.S.A. 42.6831 Clubmans Rear Mudguard
Gold Star DBD 32/34, Chrome, Replica.
Illustration no.75.

75.00

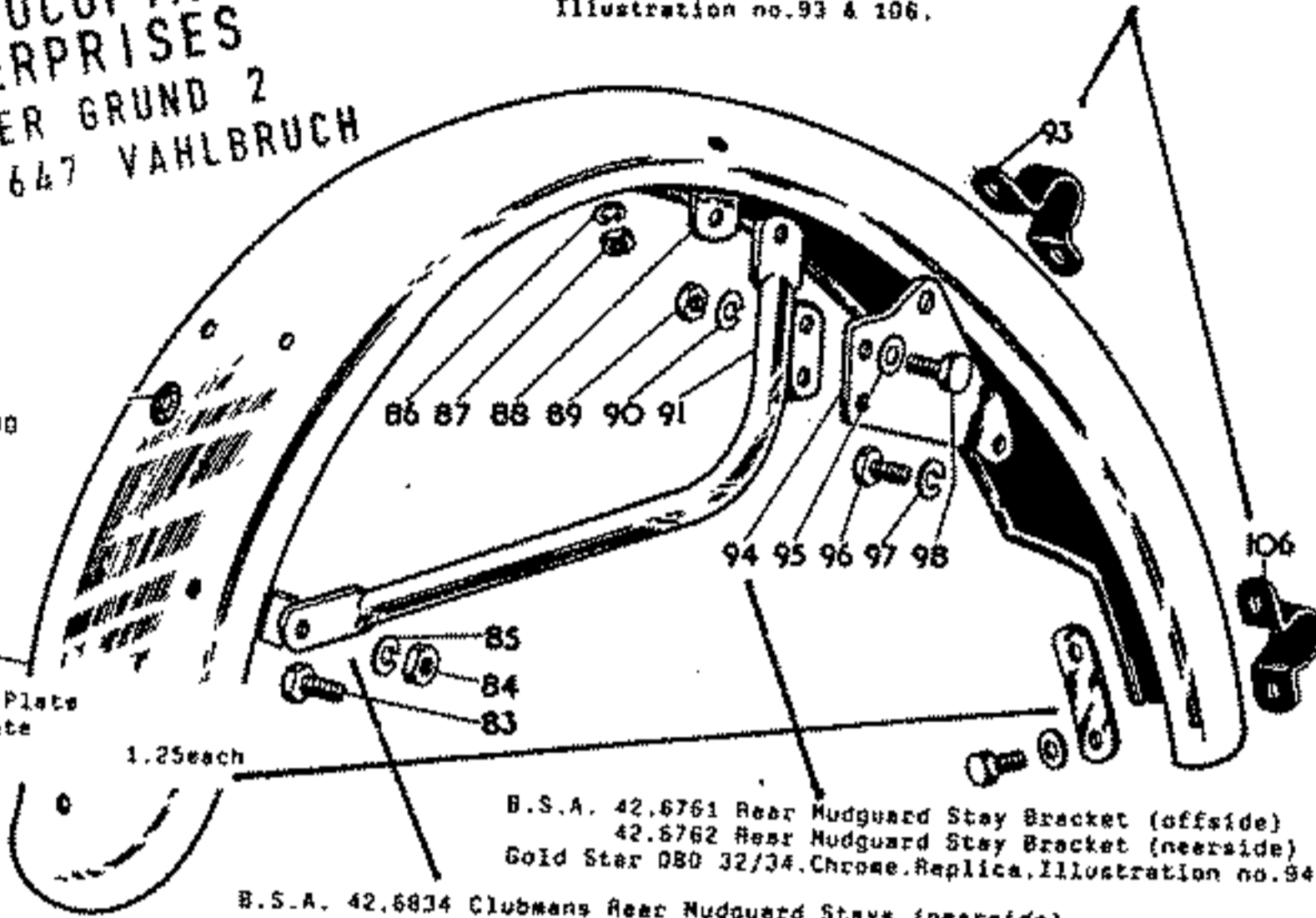

75

1.25 each

B.S.A. 42.6761 Rear Mudguard Stay Bracket (offside)
42.6762 Rear Mudguard Stay Bracket (nearside)
Gold Star DBD 32/34, Chrome, Replica, Illustration no.94.

14.00 pair

B.S.A. 42.6834 Clubmans Rear Mudguard Stays (nearside)
42.6835 Clubmans Rear Mudguard Stays (offside)
Gold Star, DBD 32/34, S.Arm models, Chrome, Replica.
Illustration no.91.

42.00 pair

B.S.A. 42.9203 Clubmans Top Headlamp Bracket
Gold Star DBD 32/34, Replica, Two needed, Illustration no.17.

6.00 each

B.S.A. 42.9116 Clubmans Top Headlamp Bracket Clip
Gold Star DBD 32/34, Replica, Two needed, Illustration no.20.

6.00 each

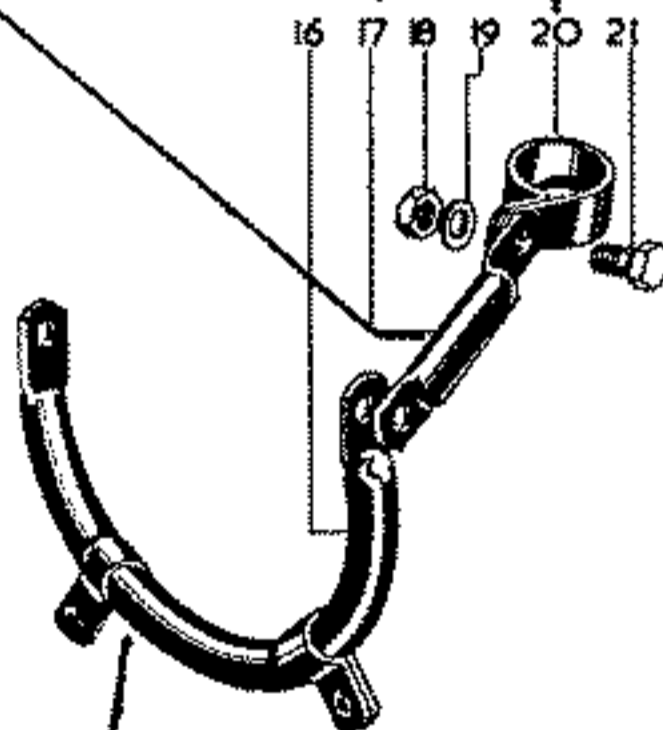

B.S.A. 42.9204 Clubmans Lower Headlamp Bracket with clips
Gold Star DBD 32/34, Replica, Illustration no.16.

22.00

B.S.A. 42.6511 Clubmans Centre Front Mudguard Stay
Gold Star DBD 32/34, Chrome, replica, Illustration no.34.

25.00

B.S.A. 42.6510 Front Mudguard Clubmans Bottom Stay
42.6510 Front Mudguard Clubmans Top Stay
Gold Star DBD 32/34, Chrome, Two needed Illustration

no.36 & 27 20.00 each

B.S.A. 42.4148 Rear Suspension Outer Shroud Cover
Gold Star, 350cc, 500cc scramblers & clubmans, 1952, 53.
To fit Girling or Armstrong units - 2 3/4 inch DIA. -
Note-later units smaller DIA. Genuine.

12.00 each

B.S.A. 19.1472 Horn Push Button (replica)
Gold Star 350cc, 500cc, 7/8 DIA chrome.

9.00

Gold Star Kick Start Crank Spindle
Pt. no. 42-3163. (Replica) Euros 68.85

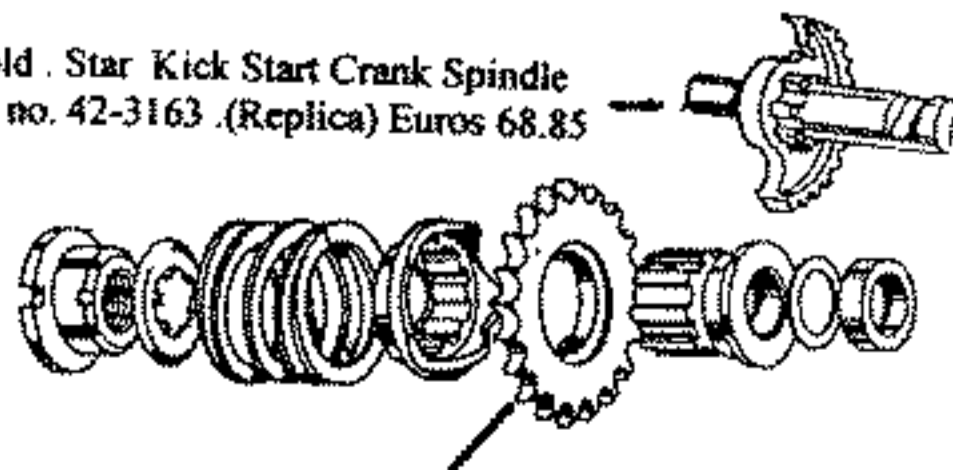

B.S.A. 65.2511 2-Lobe Engine Sprocket
A7, A10 Gold Star, 500cc G/Star (Clubmans)
16 Teeth, 19T, 20T, 22T, 23T.

35.00

B.S.A. 42.4149 Rear Suspension Inner Cover
Gold Star 1952, 53, scramblers & clubmans models.
2 1/2 inch DIA. Note-above only fitted to early
gold stars & later scramblers, girling or armstrong
units. Genuine.

10.00 each

GEARBOX
BOÎTE DE VITESSES
GETRIEBEGEHÄUSE
CAJA DE VELOCIDADES

CORNUCOPIA
ENTERPRISES
IN DER GRUND 2
D-37647 VAHLBRUCH

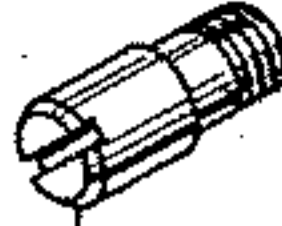

B.S.A. 67.3113 Gear Control Cam Plate
A7,A10 Fits Rigid & Plunger Models. 25.00 New
14.00 Used

67-3170

67-3342

67-3335

67.3327

67-3116

67-3332

24-868

67-3341

42-7509
(2)

B.S.A. 67.3116 Gear Shifter Fork Shaft
A7,A10 plunger,rigid & S.arm models.

12.00 new
6.00 used

67-3378

67-3204
(2)

67-3353

B.S.A. 67.3180 Clutch Operating Lever
A7,A10 Rigid,plunger & S.Arm. (unplated)
1950-63.

14.00

B.S.A. A7 A10 S.Arm Gearbox Cam Plate
67.3332 1954-63

14.00 used
25.00 new

B.S.A. A7 A10 S.Arm 67.3335 Gear Change Spindle
1955-63

25.00

B.S.A. A7 A10 S.Arm 67.3342 Gear Selector Plate Spring
1955-63 (Replica Part)

1.70

B.S.A. A7 A10 S.Arm G/Change Spring
67.3378 1955-63 Replica Part

3.25

B.S.A. A7 A10 S.Arm G/Change Spindle Inner Case Bush
67.3170 1955-63

3.50

B.S.A. A7 A10 S.Arm G/Change Spindle Outer Case Bush
67.3353 1955-63

4.50

B.S.A. A7 A10 S.Arm G/Change Shaft Selector Fork
67.3341 1955-63

14.00

B.S.A. 42.7509 A7 A10 Inner Primary Chaincase-
to Crankcase Gasket,
1954-63 (two needed)

2.00 each

B.S.A. A7 A10 S.Arm Cam Plate Rivet Pin
67.3327 1954.63

3.00

Various A7/A10 Rigid & Plunger
& S. Arm piston rings

Separate oil & comp. rings in stock.
State oversize wanted. 4.50 each.Sat Rings 26.00

B.S.A. 24.4217 Mainshaft Bearing
A7,A10.Fits Plunger & S.Arm Models

9.50

B.S.A. 67.3028 Mainshaft Bearing Spring Ring
A7,A10.Fits Plunger & S.Arm Models

5.00

67-3199 Gear control cam plate plunger
Gear control cam plate plunger housing
S.Arm & plunger models 6.00

BSA 500 O.H.V. TWIN model A7

B.S.A. 24.4065 Constant Mesh Gear Ball Bearing
A7,A10.Fits Plunger & S.Arm Models.

20.5

B.S.A. 67.3067 Gearbox Sprocket Oil Seal
A7,A10.Fits Plunger & S.Arm Models

6.50

B.S.A. 67.3026 Ball Bearing Spring Ring
(High Gear Bearing)A7,A10.Fits Plunger
& S.Arm Models.

6.0

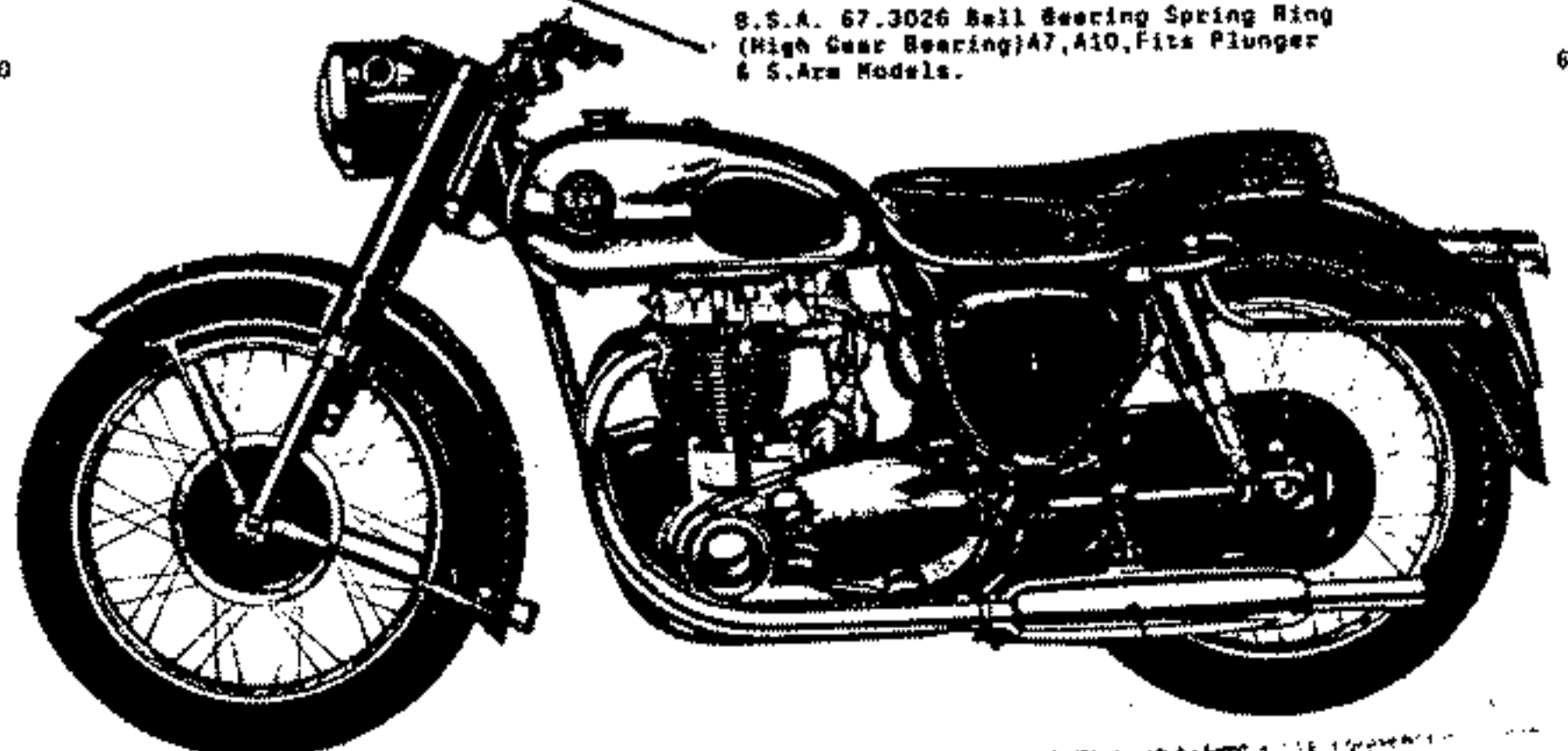
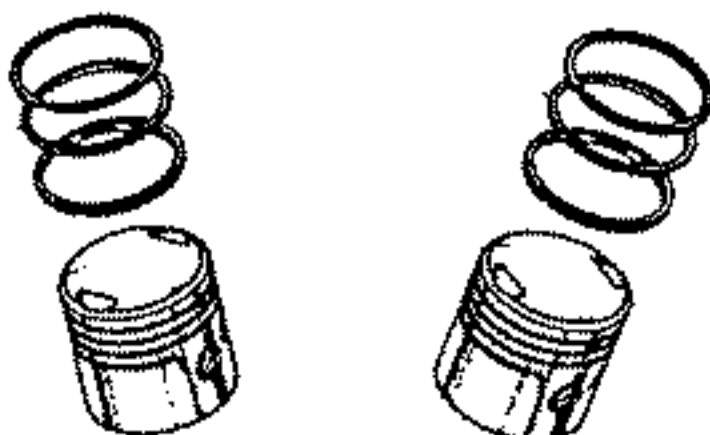

Many parts listed are available used, please enquire



650 OHV TWIN MODEL A10 SUPER ROCKET

ORNUCOPIA
ENTERPRISES
IN DER GRUND 2
D-37647 VAHLBRUCH

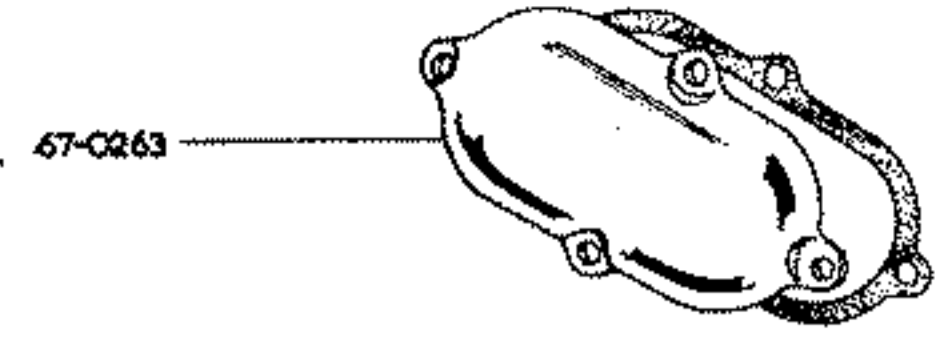
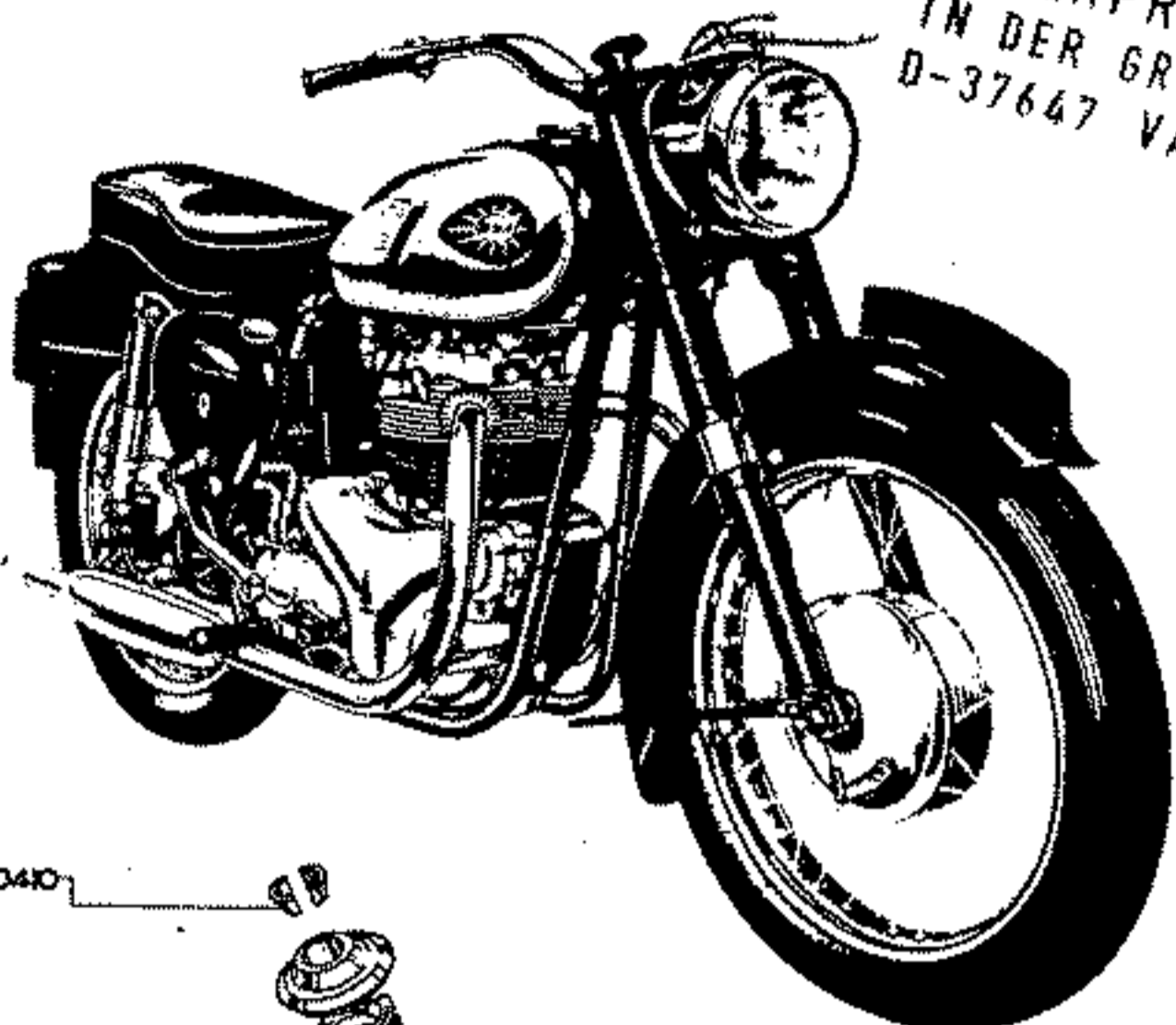

67-0263 B.S.A. 67.0263 Rocker Inspection Cover A7,A10 Plunger & S.Arm models.1958-63. used 6.00 each



29.7564 B.S.A. 29.7564 Pillion Footrest Swivel Bolt 31/32x5/16 Dome Head (Genuine BSA) All models C10,C11,B31,32,33,34,M20,21,A7,10, Gold Star B32 D8B34 1948-63. 2.48 5/16 cycle nut to fit above (replica). 2.25 Each 0.20

29.7581 B.S.A. 29.7581 Rear Footrest Arm A7,A10 Also fits B31,33,34 Gold Star-D8B 32,34.Genuine. 10.00 each

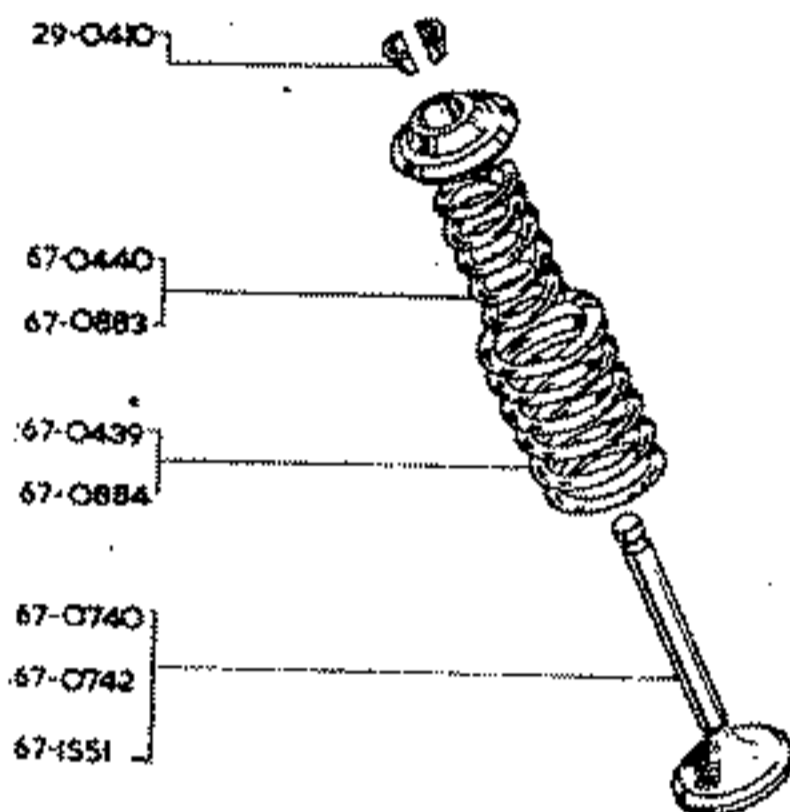

67-0883 B.S.A. 67.0883 Valve Spring Inner A10 650cc Super Rocket. (Alloy C.Head) 30.00 per set

67-0884 B.S.A. 67.0884 Valve Spring Outer A10 650cc Super Rocket. (Alloy C.Head) Limited amount in stock. Springs also sold separately.

29.410 B.S.A. 29.410 Valve Cotter A7,A10 fits Rigid,plunger & S.Arm models. 1948-63. 2.00 per pair pro pair

65.615 B.S.A. 65.615 Crankshaft Oil Hole Grub Screw A7,A10 Fits rigid,plunger & S.Arm models. 1948-63. (Genuine BSA). 4.50

67.644 B.S.A. 67.644 Crankshaft Nut Locking Washer A7,A10 fits rigid,plunger & S.Arm models. 1.70

19.1492 B.S.A. 19.1492 Dynamo Gasket A7,A10 fits rigid & S.Arm models.1947-63 1.20

67.1842 B.S.A. 67.1842 Crankshaft Oil Pump Pinion A7,10 1948-63.used. 20.00

67.45 B.S.A. 67.45 Inlet Rocker (nearside) 20.00

67.46 B.S.A. 67.46 Inlet Rocker (offside) 20.00

67.47 B.S.A. 67.47 Exhaust Rocker (nearside) 20.00

67.48 B.S.A. 67.48 Exhaust Rocker (offside) 20.00

A7 Star Twin 1947,48,49,50.

67.0056 B.S.A. 67.0056 Tappet Screw A7 & A10 1947-1963. 3.00 each

24.0563 B.S.A. 24.0563 Tappet Screw Nut A7,A10 fits Rigid,plunger & S.Arm models. 1947-1963. 0.60 each

67.0031 B.S.A. 67.0031 Valve Guides, Iron Heads A7,A10 plunger & S.Arm models.1950-63. Four needed. 5.80 each

67.0742 B.S.A. 67.0742 Inlet Valve, Iron Heads A7,A10 Plunger & S.Arm models.1950-63. 12.00 each

67.0743 B.S.A. 67.0743 Exhaust Valve, Iron Heads A7,A10 Plunger & S.Arm models.1950-63. 13.00 each

Various A10 Piston Rings, separate oil & comp. rings in stock. State oversize wanted. 4.50 each. Set Rings 26.00

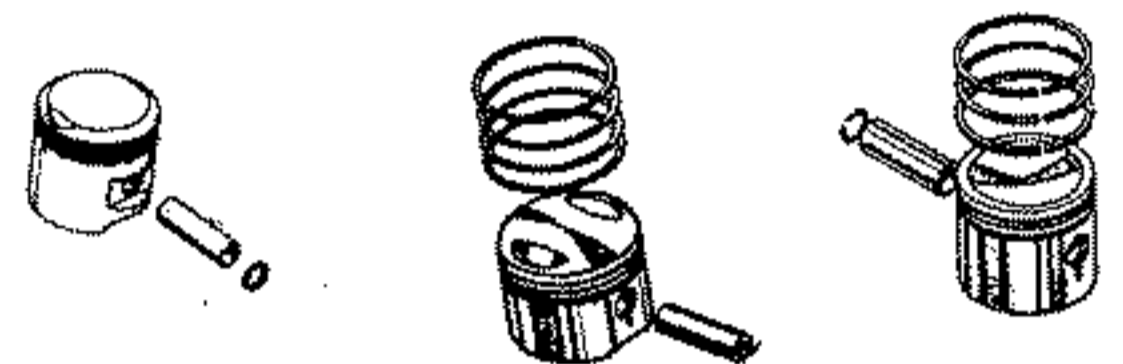

67.64 B.S.A. 67.64 Valve Rocker Spindle A7,A10 Fits Rigid,Plunger & S.Arm Models 1949-63. 16.00

67.266 B.S.A. 67.266 N/Side Exhaust Rocker A7,A10. 20.00 Each

67.264 B.S.A. 67.264 N/Side Inlet Rocker A7,A10. 20.00 Each

67.267 B.S.A. 67.267 O/Side Exhaust Valve Rocker. 20.00 Each

67.265 B.S.A. 67.265 O/Side Valve Rocker Inlet A7,A10 Fits Rigid,Plunger & S.Arm Models 1948-1963. 20.00 Each

65.311 B.S.A. 65.311 Valve Rocker Spindle Nut Fits Rigid,Plunger & S.Arm Models 1947-63. 2.00 Each

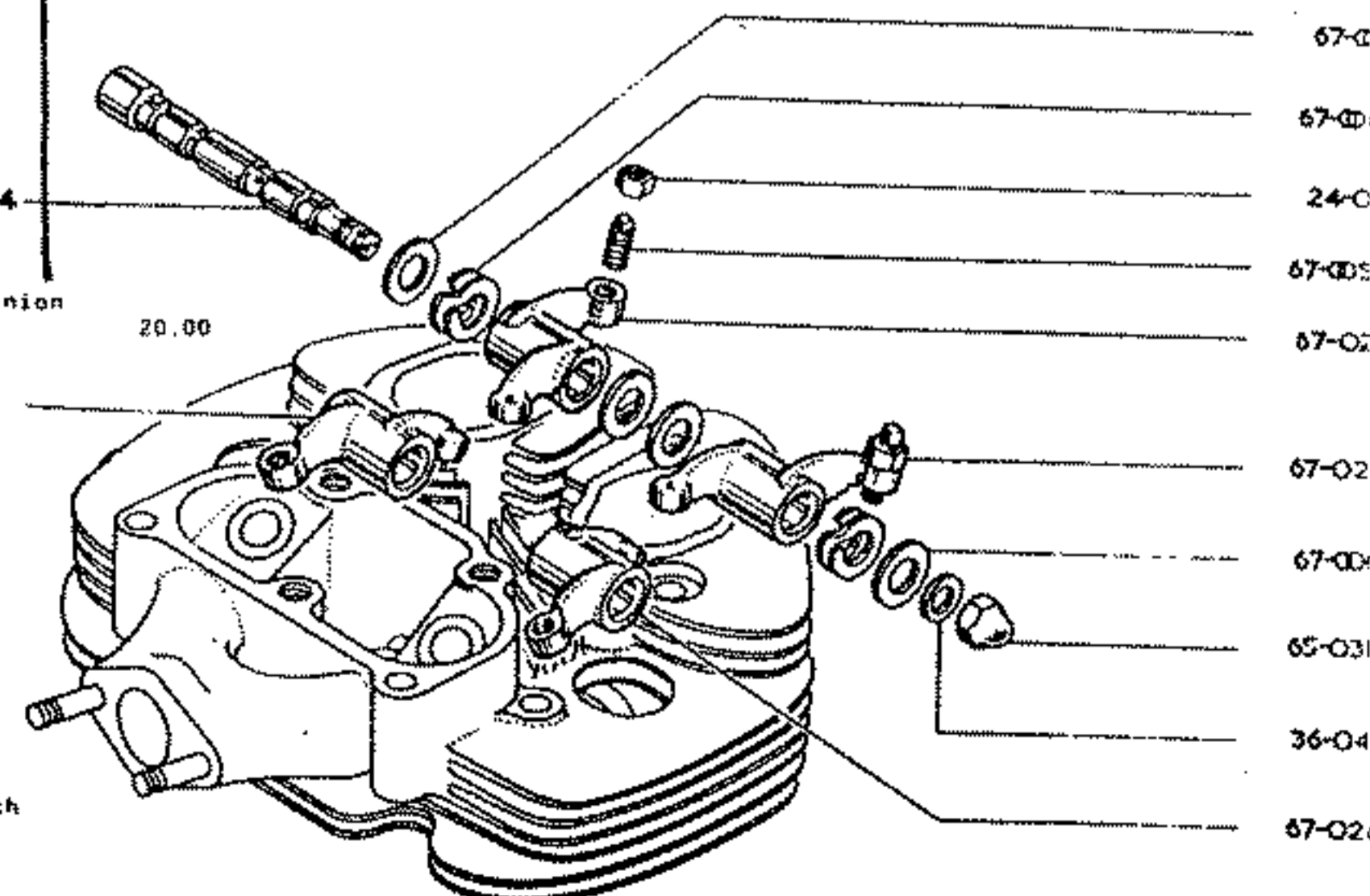

Many parts listed are available used, please inquire.



FRAME AND FITTINGS 'A' GROUP (PLUNGER FRAME)

All Parts Genuine B.S.A. unless stated

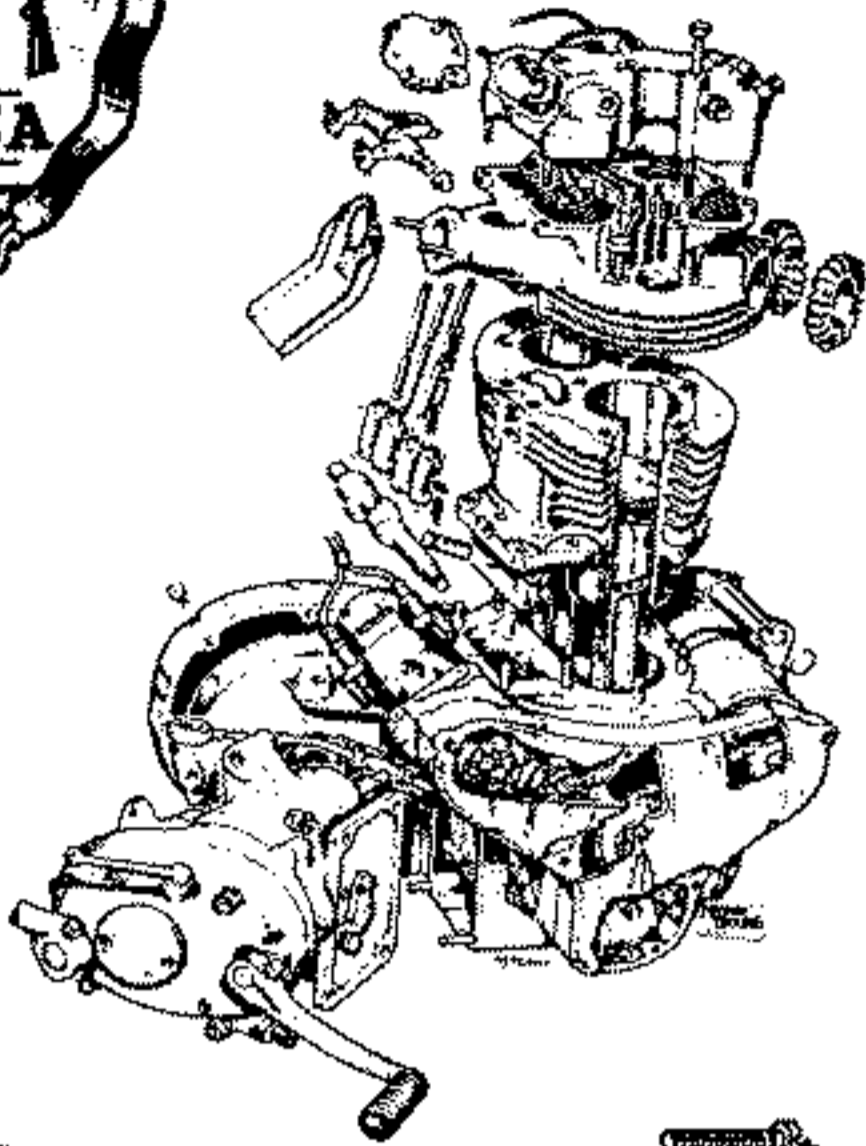

B.S.A. 67.7778 Spring Plunger frame
A7,A10 Star Twin,unpainted. Replica 46.00

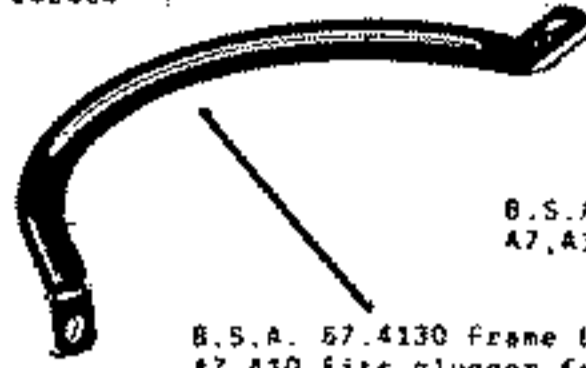

B.S.A. 67.4130 frame Lifting Handle
A7,A10 Fits plunger frame.Genuine. 20.00

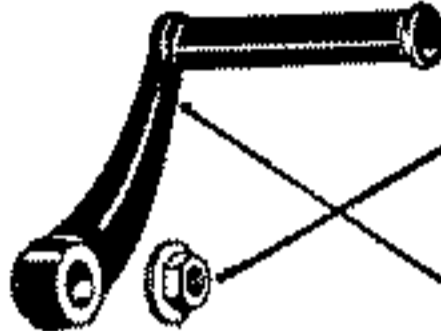

B.S.A. 67.4856 Rider Footrest Bracket Nut
Nearside. 3.00
A7,A10 plunger.1950-53.

B.S.A. 67.4851 Footrest Bracket
A7,10.Rigid & Plunger.Two needed.Used. 12.00 each

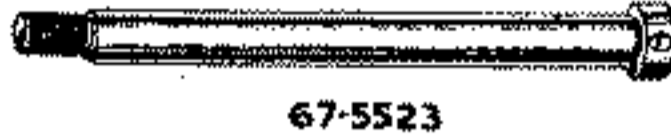

B.S.A. 67.5523 Telefork F.W. Spindle
A7,500cc Twin.1947,48,49,50.Genuine. 20.00

B.S.A. 65.6276,3,7.Rear Brake Cover Plate
831,32,33,34.Gold Star.Rigid Frame. new 25.00
1946-52.Genuine. used 16.00



B.S.A. 67.1711 Primary Chaincase Oil
Lever screw. 2.00
A7,A10.Plunger & S.arm.Genuine.

B.S.A. 67.1705 Gearbox Cover Screw(short)
A7,A10.Rigid & plunger.Genuine. 2.00

B.S.A. 65.5895 Front Brake Plate
A7,831,32,33,34.Rigid.spring & new 25.00
plunger frame.1946-53.Genuine. used 15.00

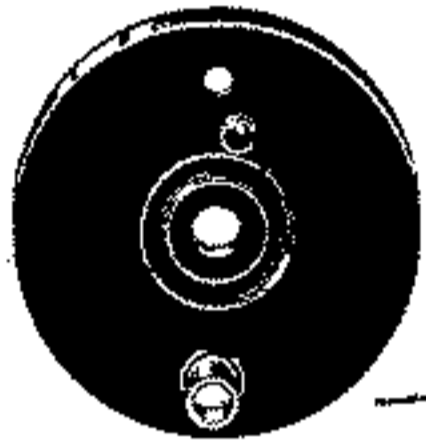

65-5895

Replica 65.2352,65.2353 Stainless Steel.
With bolt 29.4661 & Strap saddle Washer Stainless 29.4662. 10.00 set



67-4847

B.S.A. 67.4847 Centre Stand Spring
A7,A10.Plunger Frame.1950-53.Replica. 6.50



67-7006

B.S.A. 67.7006 Rear Brake Pedal Spring
A7.Rigid frame,star twin.1946-49.Genuine. 6.50

Top Battery Bracket (Pt. No A10 2.)
Must be Welded by Customer to back Plate 9.18 Euro

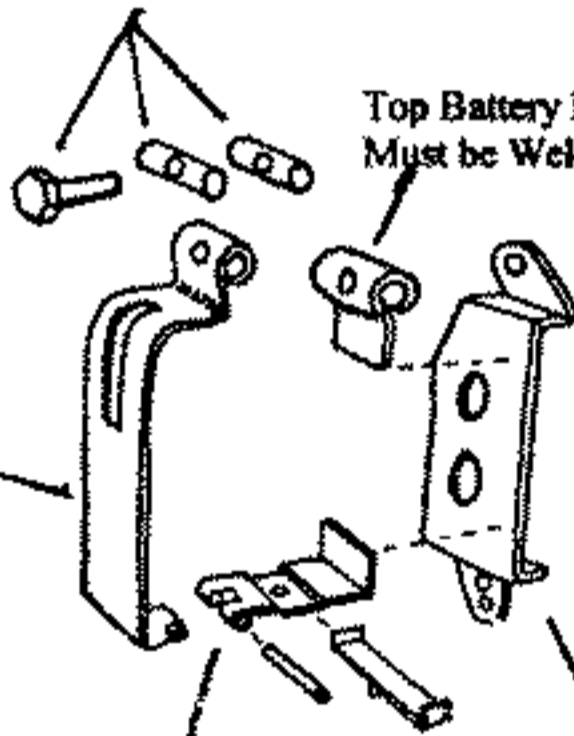

B.S.A. 28.4657 Chrome Battery Strap
C10,32,871,32,33,34,47,10,1946-53. 14.50

Stainless steel



B.S.A. 67.393 Gudgeon Pin Bush
A7 rigid.1946-50.Genuine.
Note: Bush must be reamed before fitting pin. 4.00 each

B.S.A. 67.392 Gudgeon Pin
A7 & Star Twin.1951,52.Genuine. 6.00 each

Bottom Battery Base Plate (Pt No A10.1.)
Must be Welded by Customer to back Plate 16.06 Euro

Battery Carrier Back Plate (Replica) Genuine BSA has Filter Housing attached. 21.42 Euro

CORNUCOPIA
ENTERPRISES
IN DER GRUND 2
D-37647 VAHLBRUCH

First of the sports twins was this 1949 Star Twin, which had two carburetors and was supplied in the plunger frame as standard

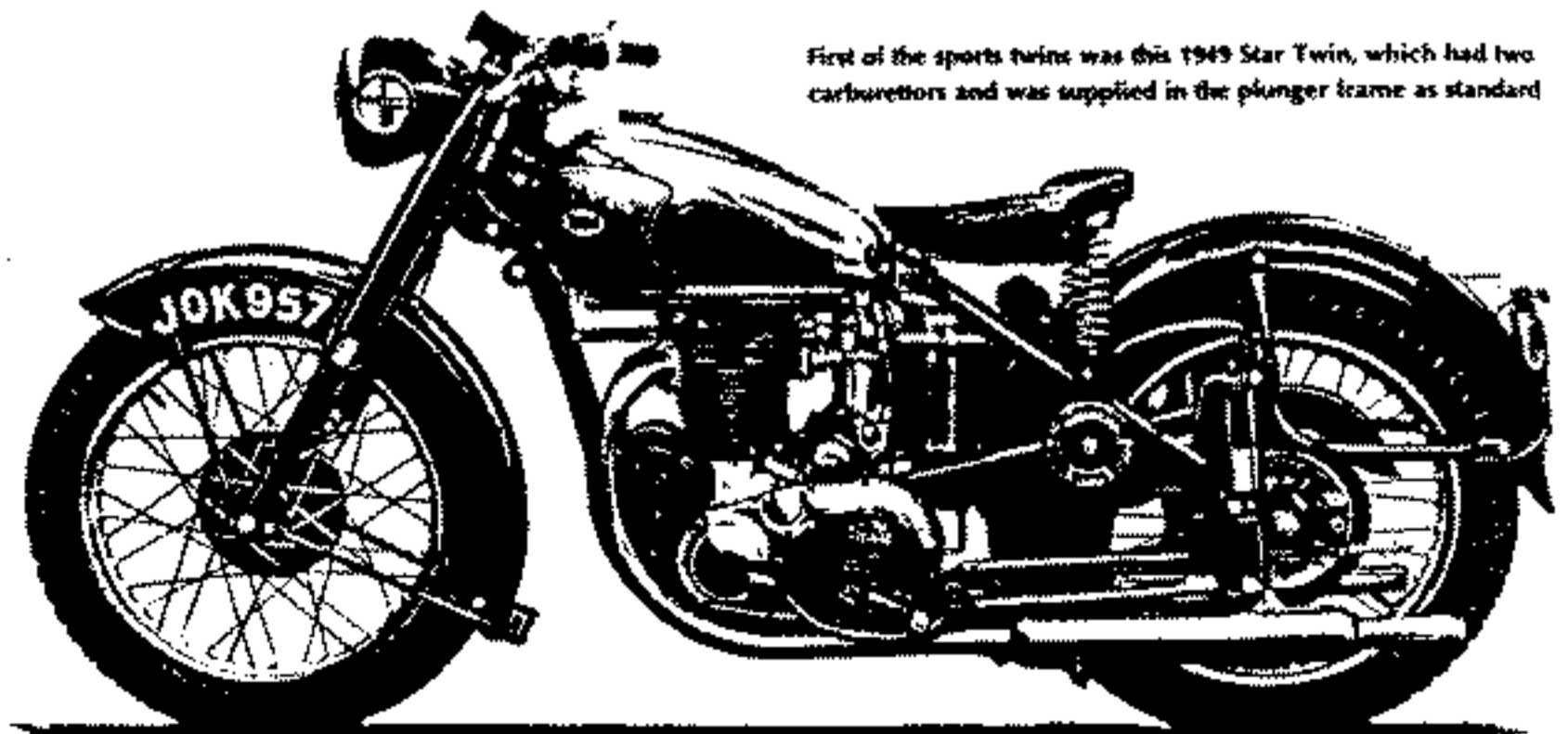

Various A7 Rigid,S.Arm models Piston Rings
Separate oil & comp. rings in stock.
State oversize wanted. 4.50 each.Set Rings 26.00

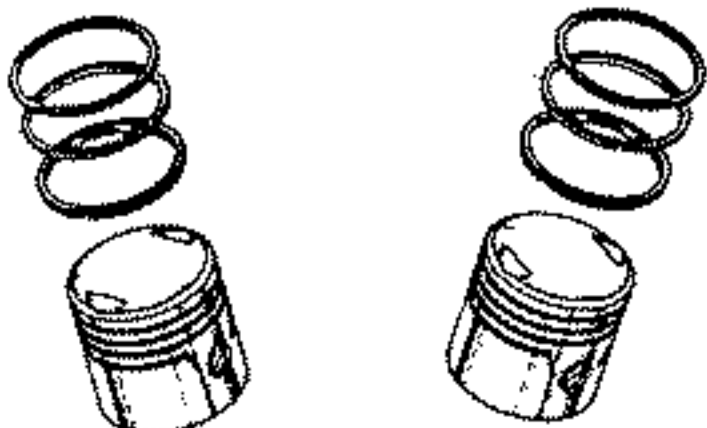

Alle Preise +versand gelten zzgl. MwSt

All prices + postage +16% VAT



BSA 650 O.H.V. TWIN model A10 Golden Flash

A7, A10 RGS, G/Star
 G.Box Sprocket
 67.3065 Solo/S.csr 19T
 67.3068 S/csr 17T
 67.3055 Spitfire Scrambler 16T.
 16T & 17T £25.00. 19T £18.00

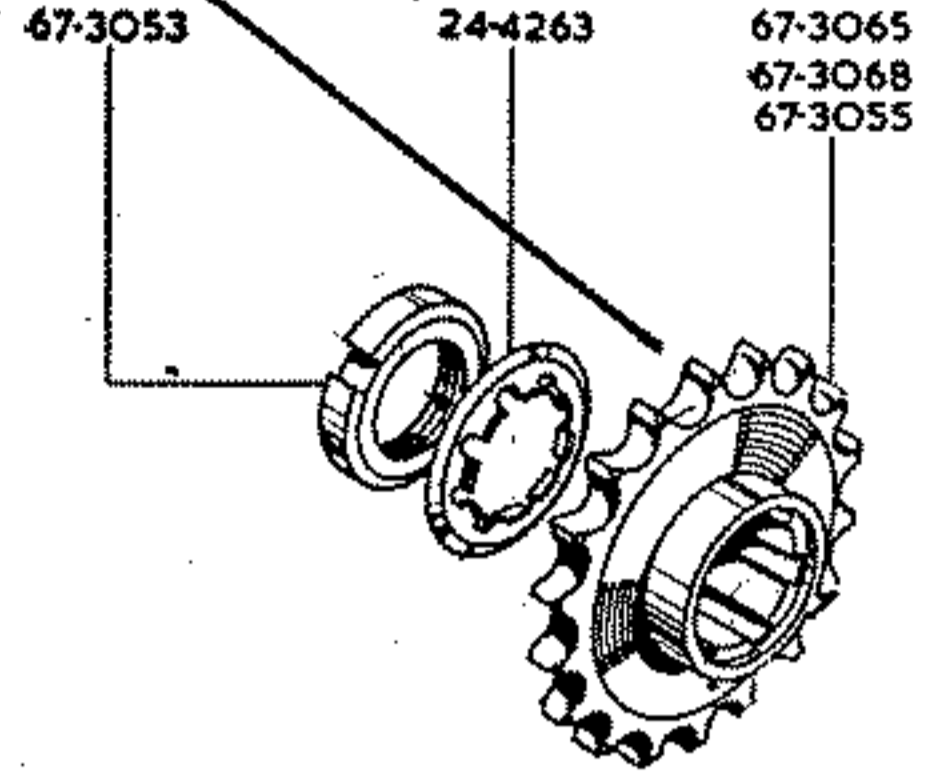
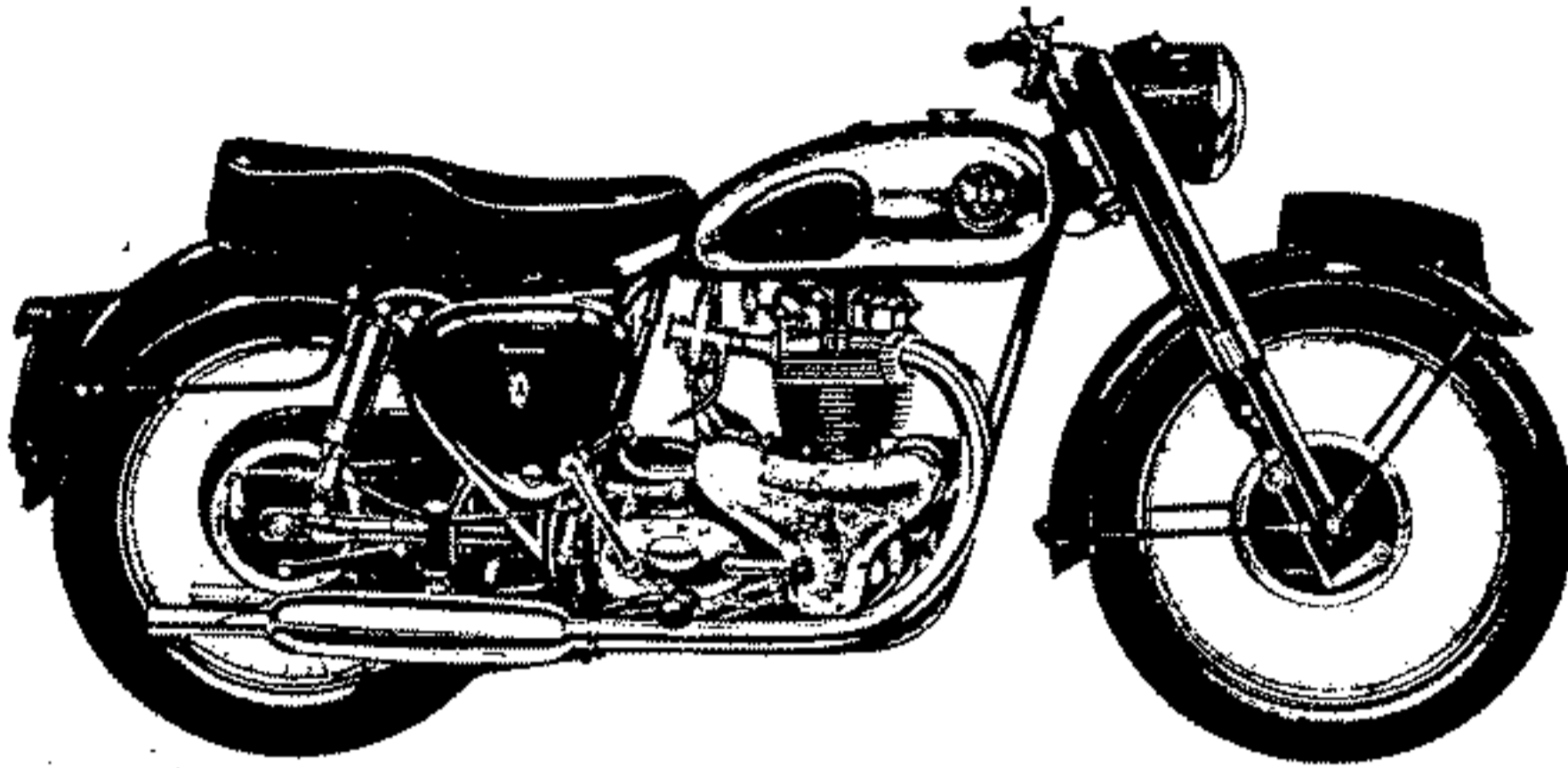

B.S.A. 67.3053 A7 A10 G.Box Sprocket Nut
 1948-63 Replica Part.
 Also fits plunger models.

6.50

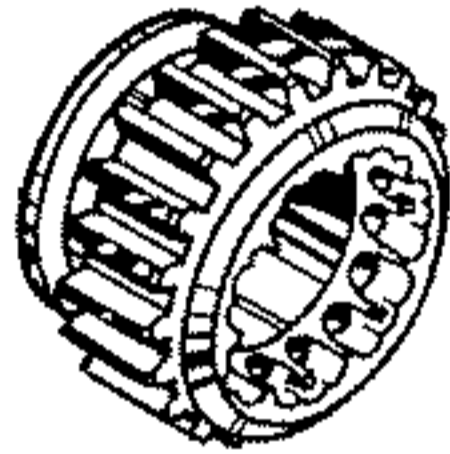
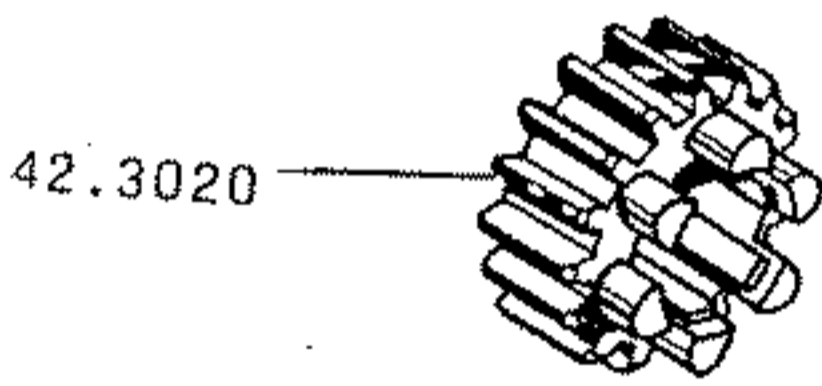

CORNUCOPIA
 ENTERPRISES
 IN DER GRUND 2
 D-37447 VAHLBRUCH

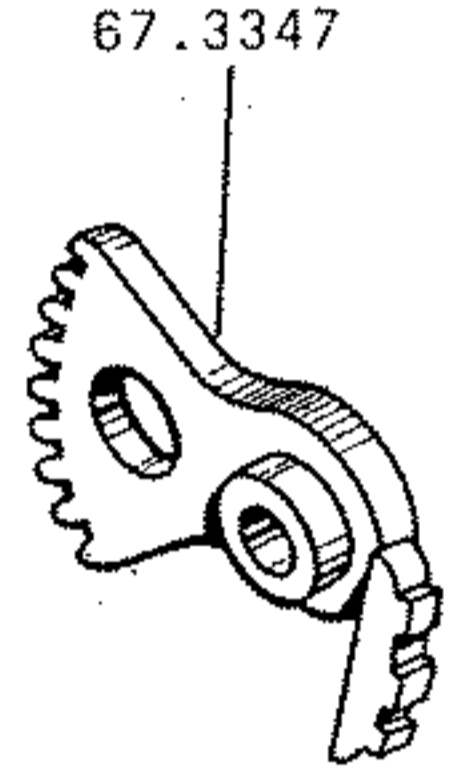

B.S.A. A7 A10 G.Box Sprocket S:Arm 67.3065 (19T)
 Replica Part Also Available 18,20,21 Teeth 19.00 each

B.S.A. A7 A10 G.Box Sprocket S:Arm Lockwasher
 24.4263 Replica Part 2.25

B.S.A. A7 A10 S:Arm 42.3020 Layshaft Pinion
 1954-63 17 Teeth 30.00

B.S.A. A7 A10 S:Arm Mainshaft Sliding Gear 24 Teeth
 67.3202 Fits Also Plunger A7 A10 G.Box 1954-63 32.00

B.S.A. A7 A10 S:Arm G/Change Quadrant
 67.3347 1954-63 16.00

All Parts New Genuine B.S.A. Unless Stated



B.S.A. 67.3175 Speedometer Drive Gear
 A7 A10 Plunger S:Arm 12T 1949-63
 (Genuine BSA) 18.00

B.S.A. 67.3377 Speedometer Gear Bush
 A7 A10 Plunger S:Arm (Genuine BSA) 3.00

B.S.A. 67.3088 Speedometer Driving Gear
 A7, A10, Rigid, Plunger & S:Arm Models, 6 Teeth 16.00

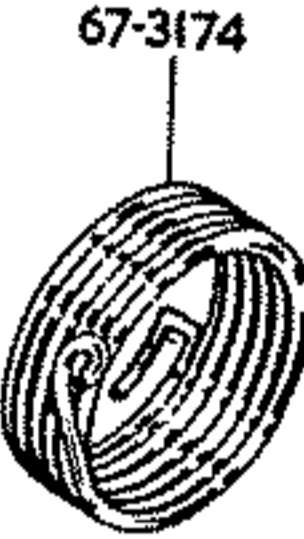

B.S.A. 67.3174 A7 A10 Kickstart Spring
 1954-63 Replica Part. 4.50



B.S.A. 67.3024 A7 A10 G/Box Inspection Cover
 1948-63 Genuine BSA, used.
 Also fits plunger models. 5.00

B.S.A. 67.0120 A7 A10 Carb Drip Tray
 1948-63 (Stainless Steel)
 Replica Part, 1 1/4 Bore.
 Fits all British motorcycles. 10.00

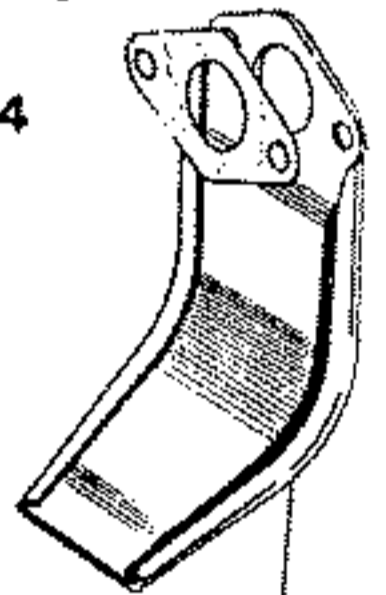

B.S.A. 67.3198 Pinion Layshaft
 A7 A10 19T 1954-63 40.00

67-3198

B.S.A. 67.3201 Mainshaft Sliding Gear
 A7, A10, Fits S:Arm & Plunger Models, 20 Teeth 42.00

B.S.A. 67.3302 Mainshaft Sliding Gear
 A7 A10 Spitfire Scrambler, Gold Star
 500cc D8D.34 19T (Genuine BSA) 48.00

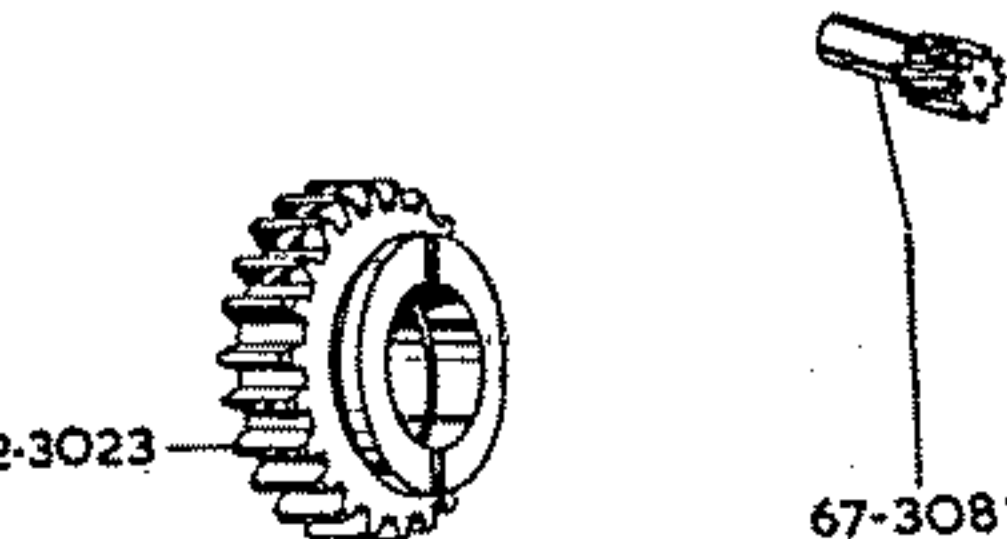

B.S.A. 42.3023 Pinion Layshaft
 A7 A10 23T 1954-63 40.00

40.00

67-3302

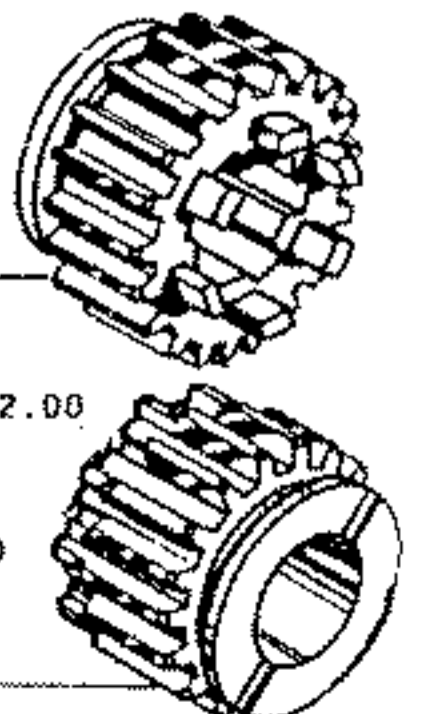

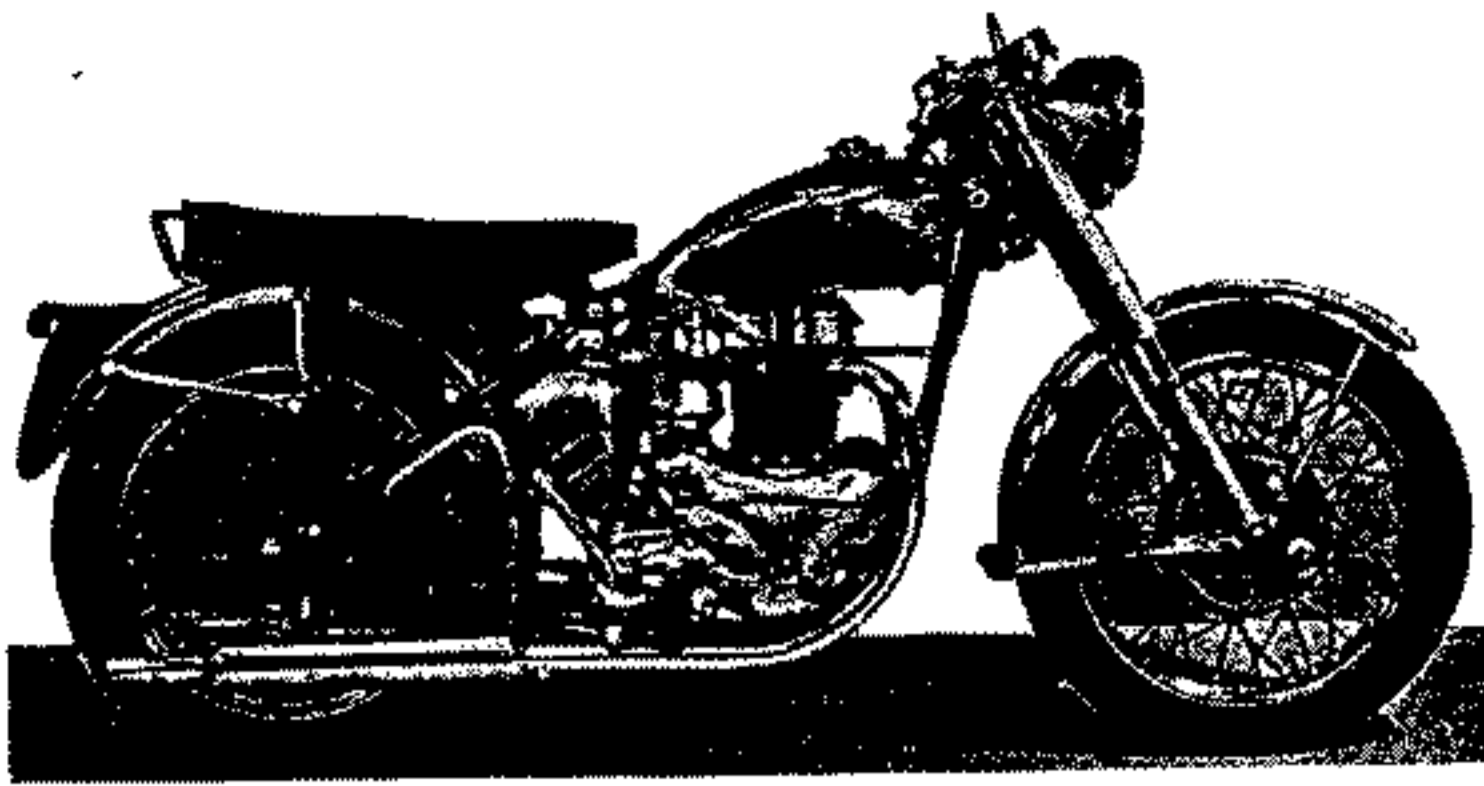

Super Flash, sporting running mate of 40 inch Golden Flash is delivered already bobbed, cammed and valved; goes like the proverbial bomb. Large front brake, new Lucas taillight are '53 advancements.

American version of A10 Golden Flash named Super Flash almost unknown in England. Not just chromed standard A10 engine. Frame Clutch easy, not interchangeable with rest of the A10 models
Super Flash Petrol tank Transfers in stock

67.6164 Gen. BSA
Rear wheel Spindles (used)
£10.00 No. 15

MARCH, 1953

67.6061 Gen. BSA
Rear Hub Bearing Distance Tube & Retainers £7.00 No. 33

67.6138
Brake Drum Securing Bolt (used) + 3.720
Fixing Nut, Bolt & Nut. 6 needed.
£3.00 ea. No. 20 & 13

89.3022 rear Sprocket Drum Bearing
£11.00 also fits all Plunger 831/33 Models

No. 16

67.6072 Gen BSA No. 17
Ball Bearing Shim for Sprocket

67.6057 Gen BSA No. 18
Circlip for Drum Sprocket Bearing
£5.00 ea.

67.6160 Gen. BSA
Rear Brake Cover Plate (used)
£ 15.00 No. 51

65.5901
Brake Shoe. Pair refined
£25.00

65.5863 Rear Hub Bearings
2 needed £9.00 ea

No 28 R/hub Bearings also fits
all S/arm 831,33,M33,
A7,A10 Twins

67.6101 (used)
Driving Flange No.19 £8.00

67.6150 Brake Drum Sprocket 46T
Plunger Models replica (used also
in stock) Various Sidecar Drum
Sprockets 50T,53T, available used
£45.00 No. 12

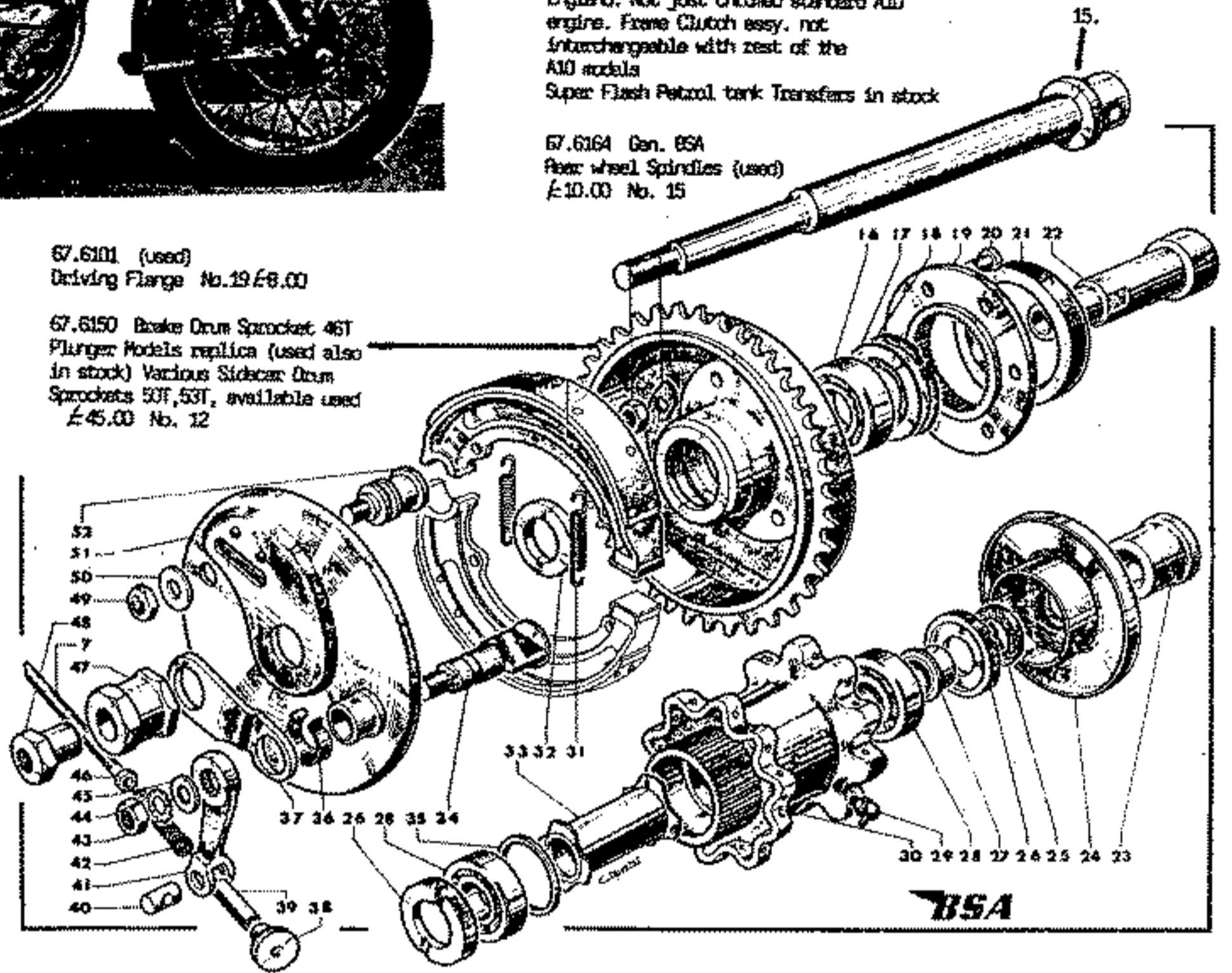

Various used parts in stock i.e. Brake
arms, Spacers, Bearing Covers, Wheel Hubs etc.

REAR HUB AND WHEEL FITTINGS 'A' GROUP (PLUNGER FRAME)

CORNUCOPIA
ENTERPRISES
IN DER GRUND 2
U-37417 VAHLBRUCH

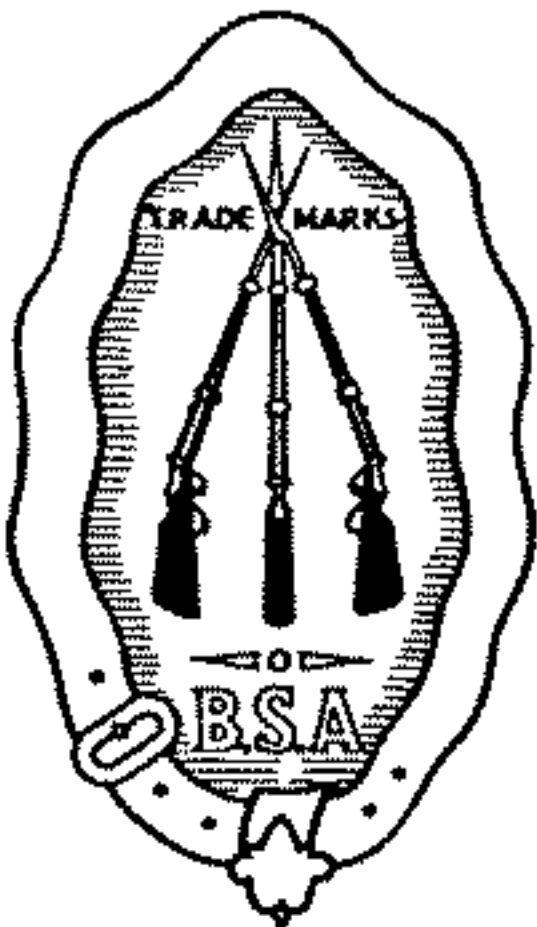

BSA

500 OHV TWINS & 650 OHV TWINS

BSA 500 OHV TWIN
model A7

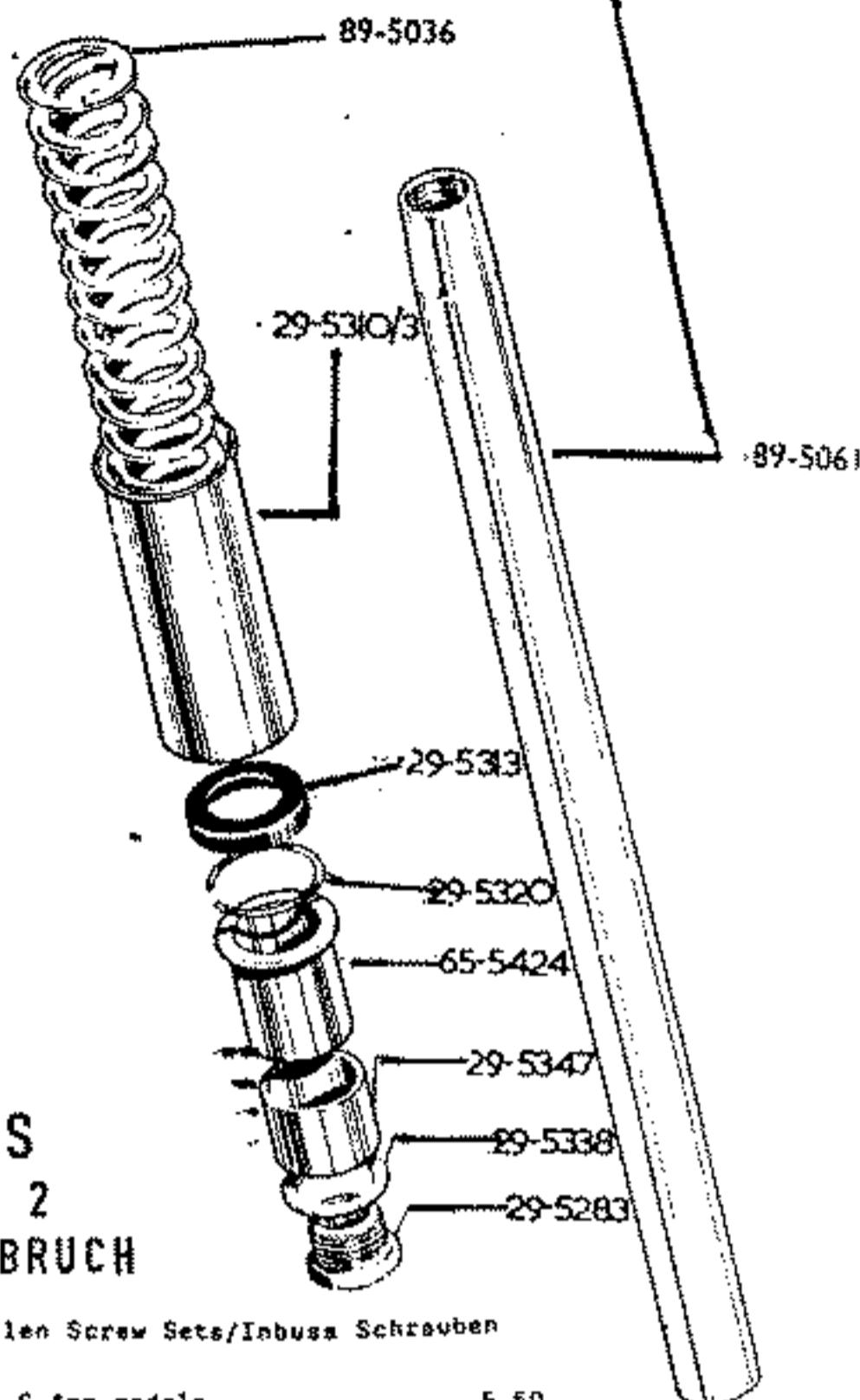
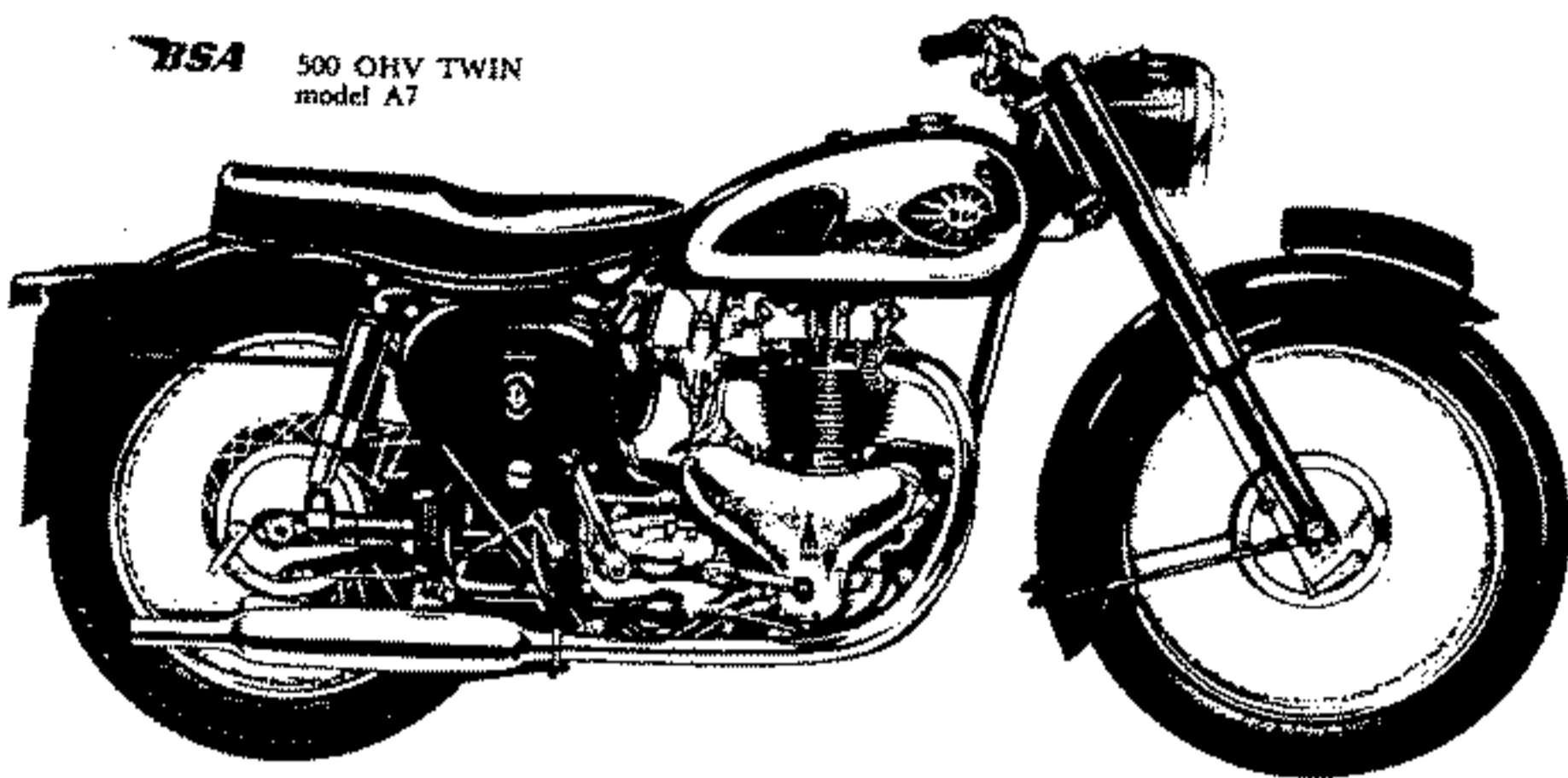

| | | | | |
|---------|-----|-----------|--------------------------|-----------------|
| A Group | ... | 29-5310/3 | Oil Seal Housing | 30.00 pair |
| A Group | ... | 29-5313 | Oil Seal | 5.00 pair |
| A Group | ... | 29-5320 | Circlip | 2.80 pair |
| A Group | ... | 29-5334 | Top Bush Shim (.005 in.) | |
| A Group | ... | 29-5335 | Top Bush Shim (.010 in.) | |
| A Group | ... | 29-5336 | Top Bush Shim (.020 in.) | |
| A Group | ... | 29-5337 | Top Bush Shim (.030 in.) | |
| A Group | ... | 89-5036 | Spring (solo) | 20.00 pair |
| A Group | ... | 89-5061 | Shaft fork Tubes | 70.00 pair |
| A Group | ... | 65-5424 | Top Bush | } 24.00 per set |
| A Group | ... | 29-5347 | Bottom Bush | |
| A Group | ... | 29-5338 | Washer | 1.50 |
| A Group | ... | 29-5283 | Plug | 66.00 pair |

CORNUCOPIA ENTERPRISES
IN DER GRUND 2
D-37647 VAHLBRUCH

Nickel Plated Allen Screw Sets/Inbusa Schrauben

| | | | |
|---------|-------------------------------------|--|-------|
| SCH10 | Timing Cover | A7, A10 Rigid, Plunger & S. Arm models. | 5.50 |
| SCH11 | Chaincase Cover | A7, A10 S. Arm model. | 8.00 |
| SCH144 | Inner Timing Cover | A7, A10 500cc, 650cc twins, late plunger & S. arm models, 1950-62. | 2.00 |
| SCH143 | Inner Timing Cover | A7, A10 Rigid & plunger models, 1946-51 500cc & 650cc twins. | 2.00 |
| SCH142 | Primary Cover | A7, A10 Rigid & plunger models, 500cc & 650cc 1946-53. | 6.00 |
| SCH145B | All Covers (Timing & Primary Cover) | A7, A10 Rigid & plunger models, 500cc & 650cc Twins, 1946-54. | 10.50 |



42-4730

B.S.A. 42.4730 Centre Stand Spring
A7, A10, B31 & B32, Fits all B32, B34-
Gold Star S. Arm models.

4.50

| | | | | |
|----------------|-----|---------|----------|------------|
| A Group | ... | 67-5023 | Adjuster | 8.50 |
| A Group | ... | 67-5024 | Top Nut | 9.50 |
| A7, A7S/S, A10 | ... | 42-5035 | Top Yoke | used 15.00 |
| A Group | ... | 27-5135 | Screw | 4.00 |
| A Group | ... | 64-6016 | Nut | 2.00 |
| A10S/R | ... | 65-5426 | Bracket* | 10.50 |
| A Group | ... | 15-5155 | Washer | 0.10 |
| A Group | ... | 65-5333 | Clip | 16.00 pair |
| A7, A7S/S, A10 | ... | 65-5334 | Bolt | 2.00 each |
| A Group | ... | 65-5331 | Top Nut | 13.00 pair |
| A Group | ... | 65-5332 | Washer | 1.25 |
| A Group | ... | 66-5204 | Cap | 7.00 |

Frame bearings, two needed.

46.50 per set

| | | | |
|---------|-----|---------|-------------|
| A Group | ... | 66-4149 | Bearing Cup |
| A Group | ... | 65-5126 | Top Cone |
| A Group | ... | 65-5127 | Bottom Cone |
| A Group | ... | 01-4675 | Ball |

66-4149

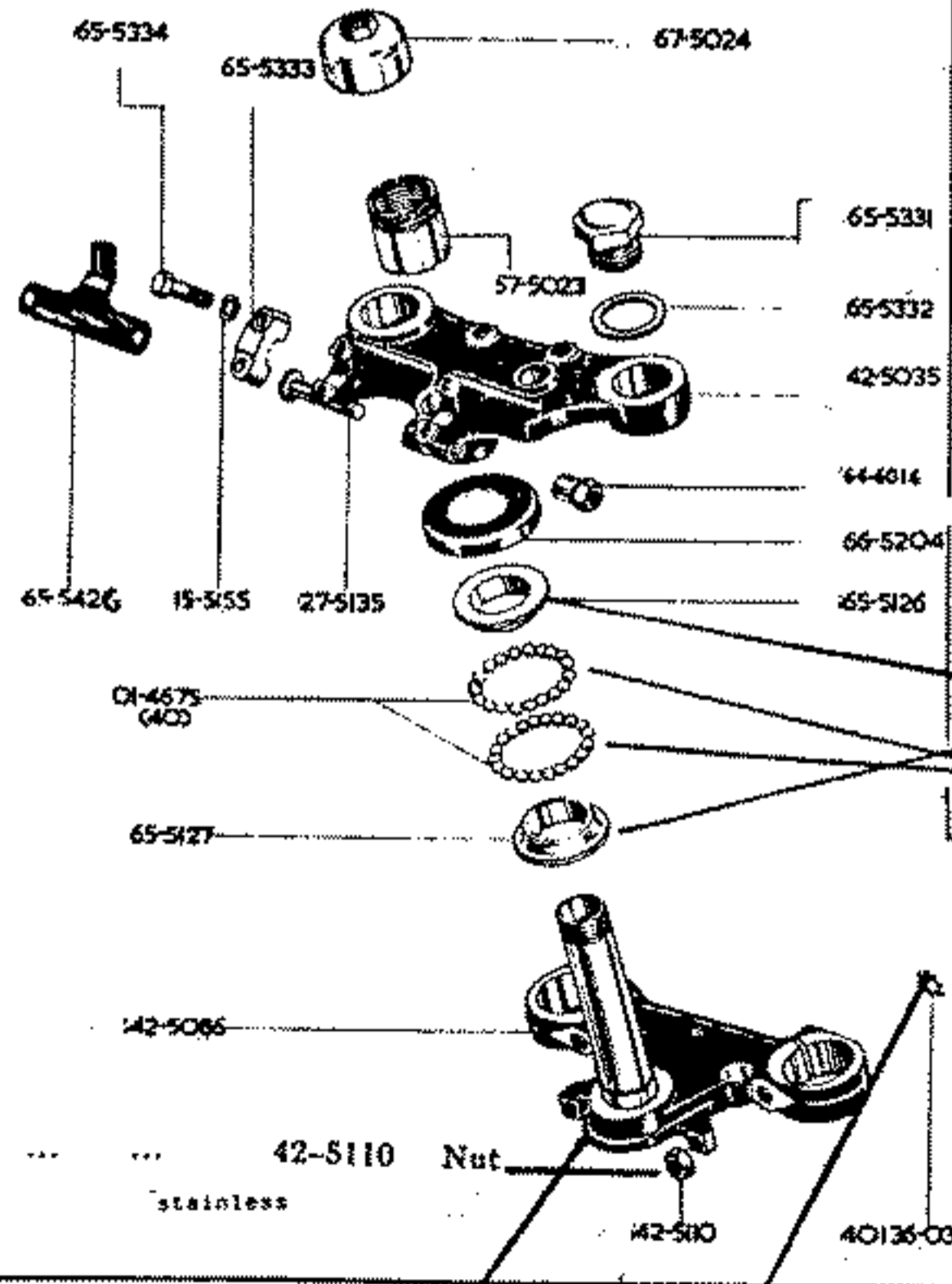

| | | | | |
|---------|-----|---------|-----|-----------|
| A Group | ... | 42-5110 | Nut | stainless |
|---------|-----|---------|-----|-----------|

B.S.A. Silencer Brackets (Zink Plated)
fits 250cc
C15, B25, B44, B31, B33, A7, A10, A50, A65
£ 4.00 each



44-2727

| | | | | |
|---------|-----|---------|-------------|------------|
| A Group | ... | 42-5086 | Bottom Yoke | used 25.00 |
| A Group | ... | 36-0382 | Lockwasher | 0.10 |

Sollten Sie etwas suchen was nicht abgebildet ist, fragen Sie bitte bei uns nach.

Many parts listed are available used, please inquire.

B.S.A. MOTORRÄDER

R=Replica G=Genuine

- B.S.A. 1948-63 A7.A10 S.Arm and Plunger Dynamo Strap 67.1876 12.00 G.
- B.S.A. 1948-63 A7.A10 S.Arm and Plunger Dynamo Strap Stud, Plunger models 3" long, 67.353, 2 needed 3.00 each G.
- B.S.A. 1948-63 A7.A10 Dynamo Chain Plunger and S.Arm 67-0296 11.50 R.
- B.S.A. 1948-63 Dynamo Strap Eye Bolt 29.2203 6.50 G.
1948-63 A7.A10 Also fits C10, C11, 1950-58 Plunger and S.Arm Models
- B.S.A. 1948-63 Dynamo Strap Plug 65.2352 1.50 R.
A7.A10 Plunger and S.Arm
- B.S.A. Nut Cycle to fit Eye Bolt 2.833 0.40 R.
- B.S.A. Washer to fit Eye Bolt 29.4662 1.00 R.
Fits all models for 1951-52
(Fits Battery Strap Bolt)

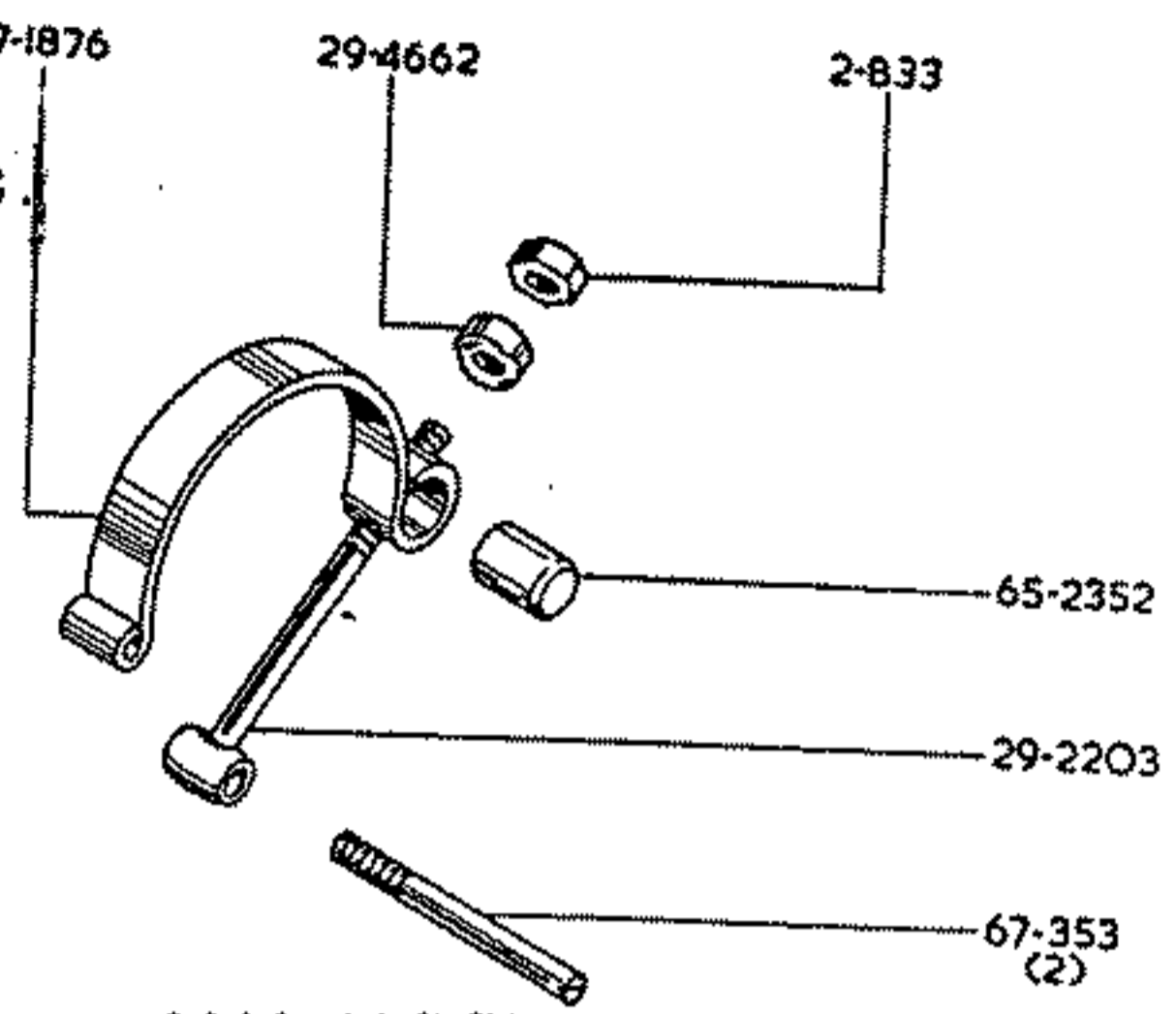

650, 500 OHV TWIN model A7 SHOOTING STAR A10 GOLDEN FLASH

- B.S.A. Crankshaft Shim 6.50
67.672 "010"
67.671 "005" 1.25 each
- B.S.A. 67.674 Crankshaft Oil Seal 6.50
A7, A10 Plunger & S.Arm models
- B.S.A. Engine Sprocket Alignment Shim A7, A10.
67.2056 "005" 1.25
67.2057 "010"
67.2058 "030" Plunger & S.Arm models
- B.S.A. 67.670 Crankcase Roller Bearing 22.00
Plunger & S.Arm models
- B.S.A. 67.1240 Crankcase Ball bearing Drive Side
A7 Rigid model, 1948-51 18.00

- B.S.A. 65.2511 2-Lobe Engine Sprocket 35.00
A7, A10 Gold Star, 500cc G/Star (Clubman)
16 Teeth, 191, 201, 221, 231.
- B.S.A. 65.2537 35.00
G/Star 080 34 & Spitfire Scrambler, 17 Teeth.
- B.S.A. 67.1132 35.00
A7, A10 S/Car Models, 18 Teeth
- B.S.A. 67.1133 35.00
A7, A10 Solo Models, 21 Teeth
- B.S.A. Rocket Gold Star, 24 Teeth 37.00

- B.S.A. 1954-63 A7, A10 Crankshaft Sleeve Bearing 42.69 18.00
- B.S.A. 1954-63 A7, A10 Crankshaft Distance Piece 67.1136 5.00

B.S.A. 67.1292 Crankcase Connecting Bolt (top) 2.50
Fits plunger & rigid models. and S.Arm

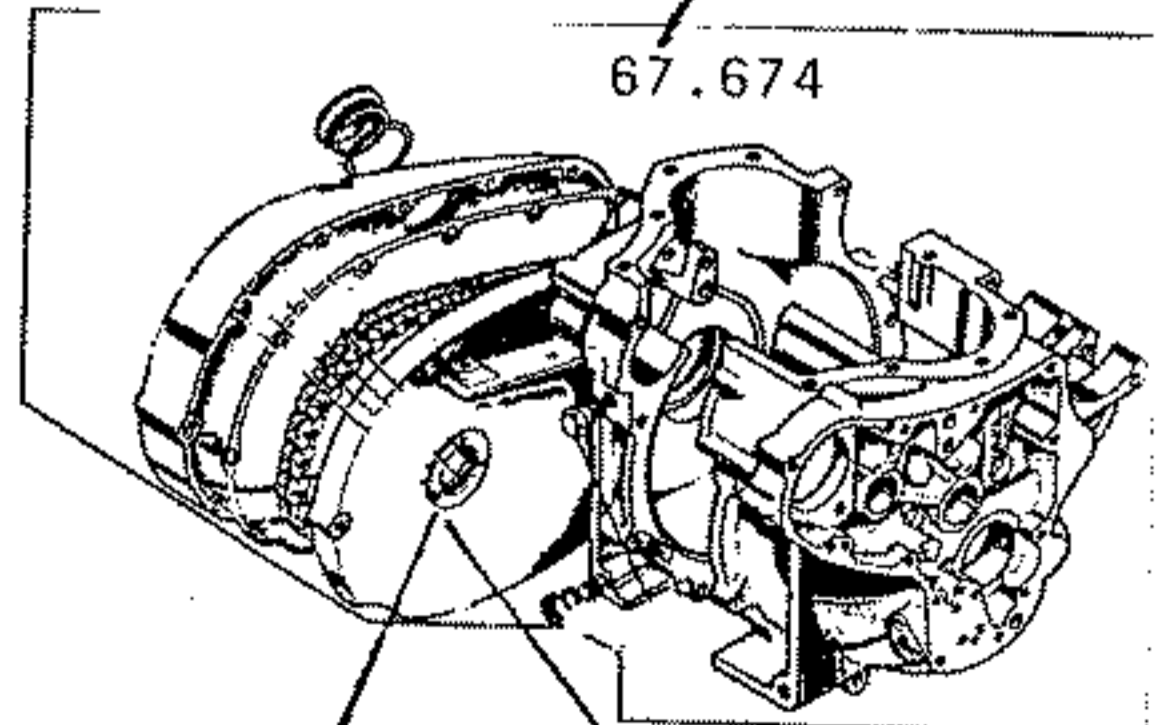
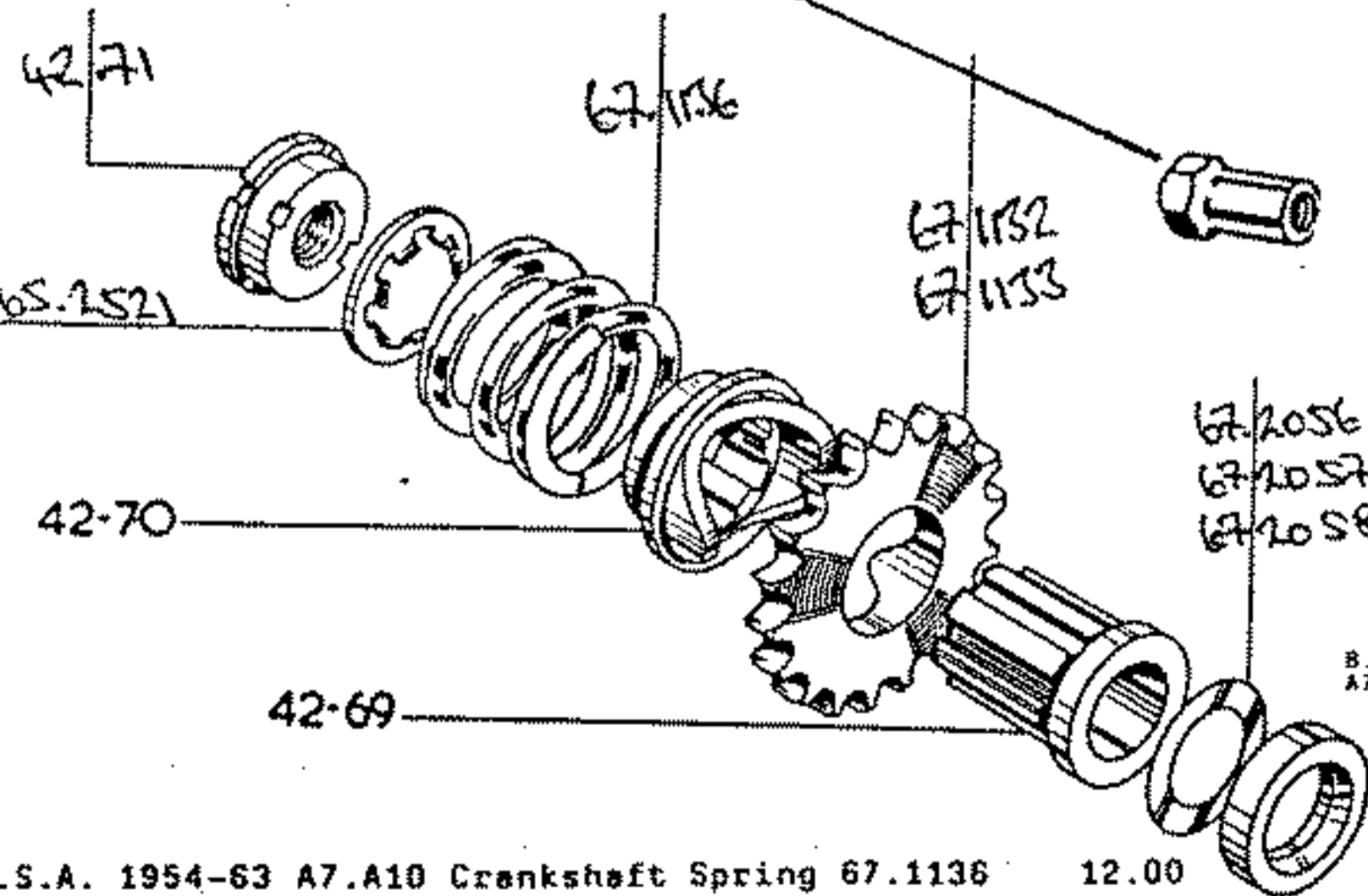
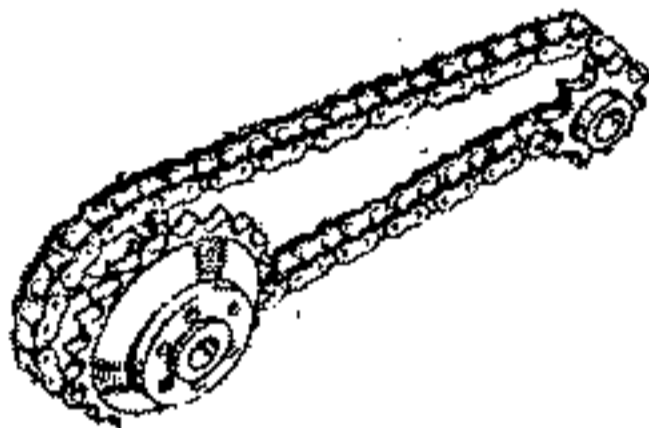

- B.S.A. 67.1244 Crankcase Oil Flinger Rivet 1.50 (pack of 3)
A7, A10 Rigid & plunger models 1946-54.
- B.S.A. 67.1243 Crankcase Oil Seal Washer 6.00
- B.S.A. 67.1241 Crankcase Oil Flinger 7.00
- B.S.A. 67.1242 Crankcase Oil Seal 3.25

Above seal is sandwiched between 67.1243 washer and 67.1241 flinger. To fit new seal rivets must be drilled to remove.

- B.S.A. 1954-63 A7, A10 Crankshaft Spring 67.1136 12.00
- B.S.A. 1954-63 A7, A10 Crankshaft Sleeve 42.70 10.00
- B.S.A. 1954-63 A7, A10 Crankshaft Nut 42.71 7.50

500 OHV TWINS & 650 OHV TWINS

CORNUCOPIA ENTERPRISES
 IN DER GRUND 2
 D-37647 VAHLBRUCH

Below The early BSA 495 cc vertical twin, as in 1947, in a field frame and with a saddle

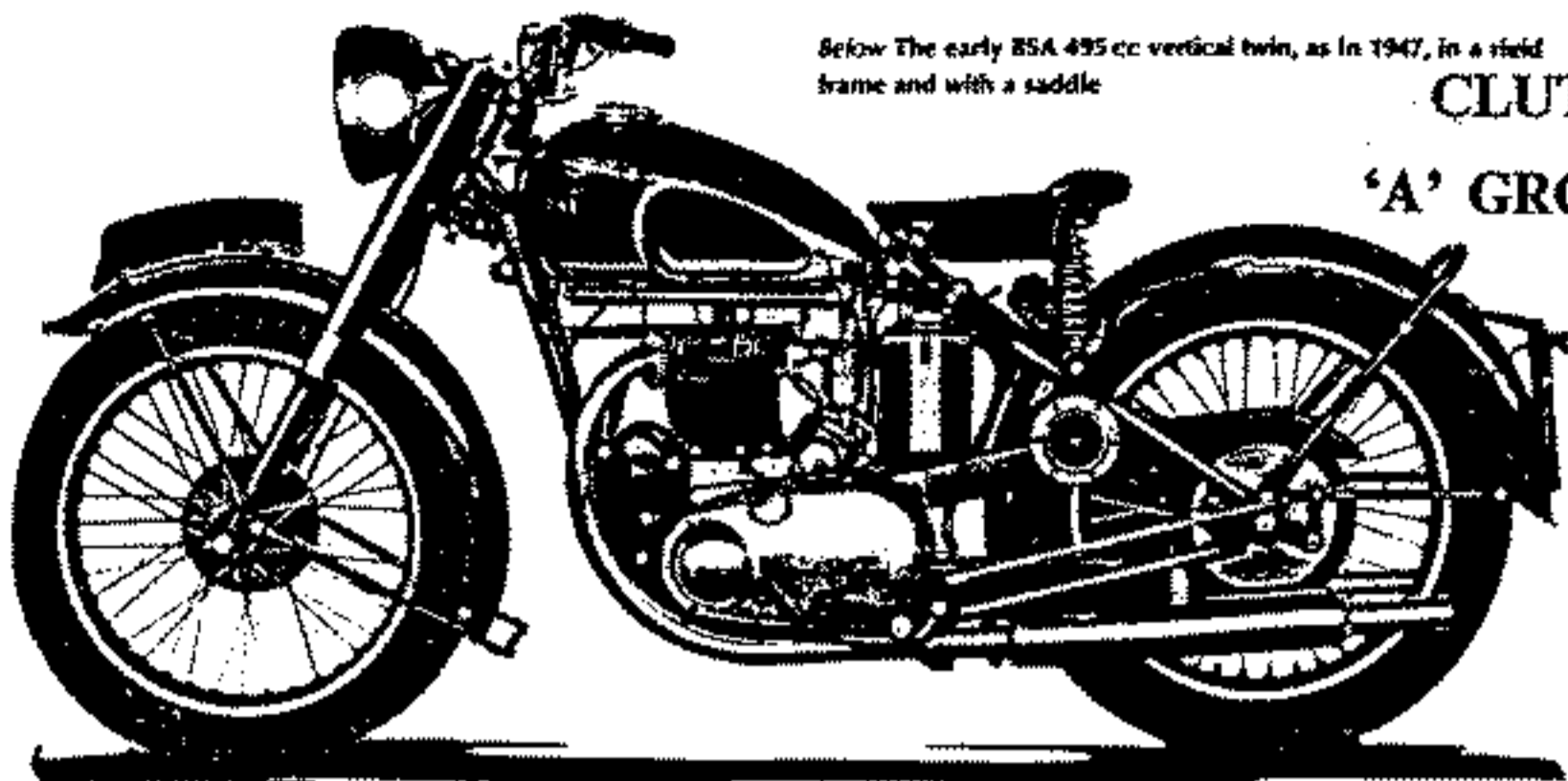

CLUTCH GEARBOX 'A' GROUP (PLUNGER FRAME)

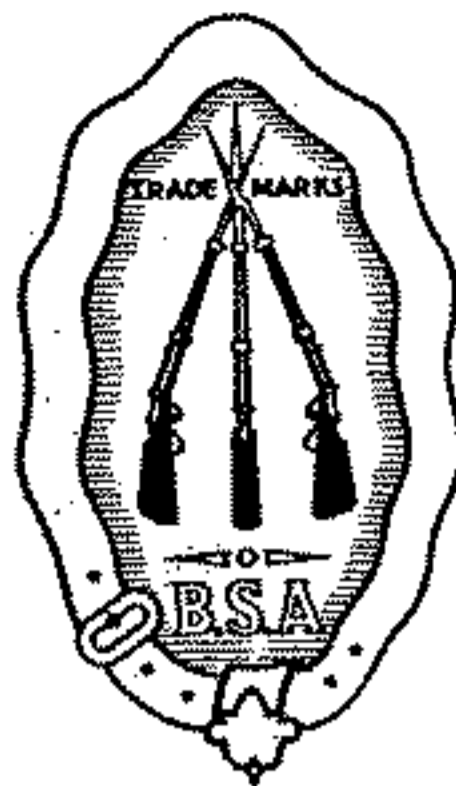

Gearbox Sprocket
 B.S.A. A.7/A.10 Plunger
 & S.Arm Models, 67.3064-
 18T. 67.3065 19T. £ 19.00

1947-48 A.7 19T, 1949 A.7 &
 A.7 Star Twin 67.3050
 £ 20.00. 1947 A.7 18T 67.3051
 £ 20.00

B.S.A. 26.650 Clutch Chainwheel Rollers
 (new replica) set of 18

5.50

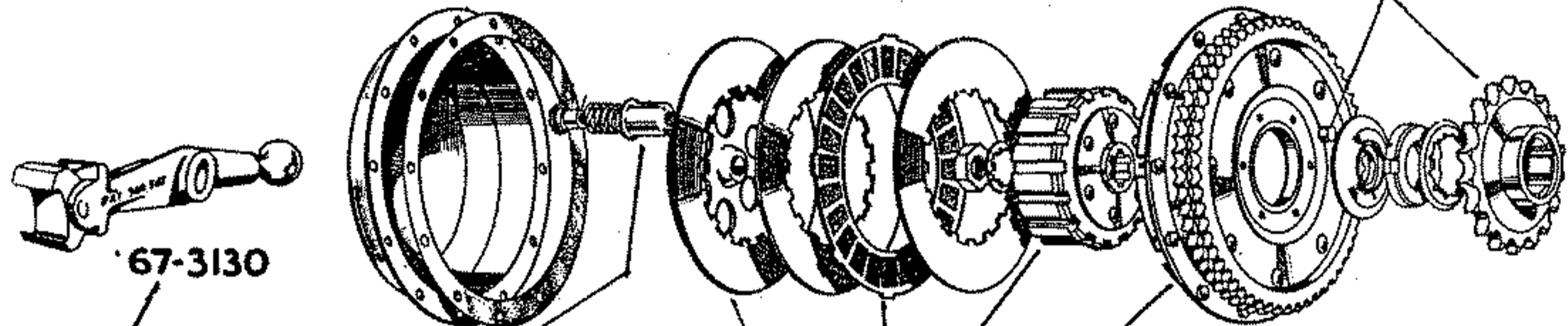

67-3130

B.S.A. 67.3130 Gearchange Selector Arm (complete)
 A7, A10 fits rigid & plunger models, 1948-54.

22.00 complete

B.S.A. 67.3248 Clutch Spring Cup (used)
 A7, A10 fits rigid & plunger, 1947-53.
 six in set.

4.00 each

B.S.A. 67.3247 clutch springs
 six in a set.

6.50 set

B.S.A. 67.3170 Footchange Spindle Bush
 A7, A10 fits Rigid, plunger & S.Arm models.
 1948-63. All S.Arm 831, 32, 33, 34 DBO Gold Stars.

4.50

B.S.A. 67.3146 Selector Lever Return Spring
 A7, A10 plunger & rigid models. (two needed).

2.25 each



67-3143

B.S.A. 67.3143 Gearchange Selector Lever
 A7, A10 fits rigid & plunger models.
 1948-54.

22.00

B.S.A. 67.3147 Gear Selector lever Spindle
 A7, A10 fits rigid & plunger models.
 1948-54.

12.00

B.S.A. 67.3131 Gearchange Selector Arm (Arm Only)
 A7, A10 fits rigid & plunger models, 1948-54.

16.00 Arm only

B.S.A. 67.3135 Gearchange Arm Plunger Spring
 A7, A10 fits rigid & plunger models, 1948-54.

1.25

B.S.A. 67.3134 Gearchange Selector Arm Plunger
 A7, A10 fits rigid & plunger models, 1948-54.

4.00

B.S.A. 67.3132 Gearchange Selector Arm Claw
 A7, A10 fits rigid & plunger models, 1948-54.

8.00

B.S.A. 67.3111 Gear Selector Cam Plate Bearing
 A7 fits rigid models, 1948-51.

14.00

B.S.A. 67.3137 Gear Selector Cam Plate Bearing
 A7, A10 fits plunger models, 1951-54.

14.00

B.S.A. 67.3151 Kickstarter Spindle Bush
 A7, A10 plunger, rigid & s.arm models.

5.00

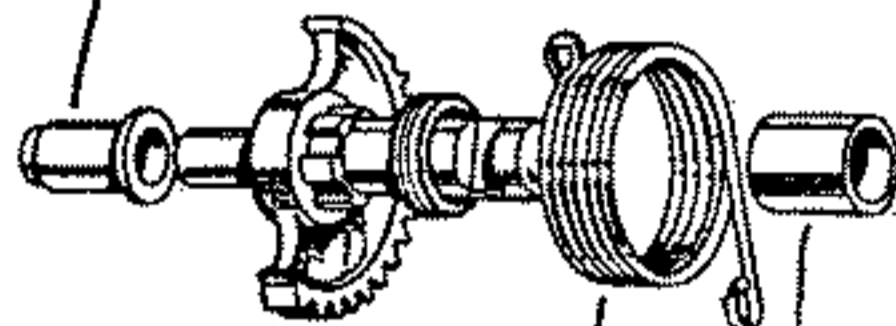

B.S.A. 67.3178 Kickstart Spindle & Quadrant
 A7, A10 plunger & rigid models.

35.00 new
 20.00 used

B.S.A. 67.3174 Kickstarter Spring
 A7, A10 plunger & rigid models. (Replica Part).

5.50

B.S.A. 67.3153 Outer Cover Kickstart Lever Spindle Bush
 A7, A10 fits rigid, plunger & S.Arm models. (replica)

6.00

B.S.A. 67.3027 Gearbox Inspection Hole Plug
 A7, A10 (gen BSA) fits rigid & plunger models.

1.50



B.S.A. 1954, 55 Kickstarter Ratchet 67.3167
 Plunger A7 A10 All S.Arm Models A7 A10 1955-63
 S.Arm Models 831, 32, 33, 34 1954-63
 Also fits 1951, 51 C10 C11 4 Speed

8.00

Sollten Sie etwas suchen was nicht abgebildet ist, fragen Sie bitte bei uns nach.

Many parts listed are available used, please inquire.